

**ENGINE**

Make	Cummins Tier III certified
Model	QSB 3.3 C99
Horsepower – Rated	99 (73.8 kW)

**ELECTRICAL**

Voltage	24 volts
Batteries	2 - 61 amp
Alternator	45 amp

**STEERING**

Pump (gear type)	1
Cylinders	2
Angle (left & right)	36°
Oscillation angle	12°
Inner turning radius	10.2 ft (3.09 m)
Outer turning radius	15.7 ft (4.80 m)

**WEIGHT**

Operating weight	19,445 lbs (8820 kg)
Max. weight	20,426 lbs (9265 kg)
Drum weight	11,718 lbs (5315 kg)
Static linear load	177 lb/in (31.6 kg/cm)
Ballast	926 lbs (420 kg)

**TRAVEL**

Hydraulic circuit type	closed
Variable displacement axial piston type wheel drive pump	1
Hydraulic fixed displacement wheel drive motors	2
Drive motor interlock	yes
Hydraulic variable displacement drum drive motor	1
F/R travel speed range	4
Working speeds – mph (km/h)	
1st (max.)	1.6 (2.5)
2nd (max.)	2.2 (3.5)
3rd (max.)	2.9 (4.7)
Max. travel speed	6.8 (11)
Gradeability	55%
Transversal stability (machine in straight line)	33°

**VIBRATION**

Hydraulic circuit type	closed
Variable displacement axial piston type pump	1
Fixed displacement hydraulic motor	1
Vibration	2 eccentric weights
Vibration modes	2
Vibration mode 1 –	
Frequency	2400 vpm (40 Hz)
Rated amplitude	.038 in (.96 mm)
Centrifugal force	32,597 lbs (145 kN)
Dynamic linear load	494 lbs/in (853 N/cm)
Vibration mode 2 –	
Frequency	1800 vpm (30 Hz)
Rated amplitude	.073 in (1.85 mm)
Centrifugal force	35,970 lbs (160 kN)
Dynamic linear load	545 lb/in (941 N/cm)

**TIRES**

Type	14.9 x 24 in 8PR Smooth drum – Diamond tread, Padfoot drum – Traction tread
Tire ballast	Yes

**CAPACITIES**

Fuel tank	72.7 gal (275 L)
Engine oil	12 qt (11 L)
Engine coolant	20 qt (19 L)
Hydraulic reservoir	77 qt (73 L)
Transmission	2.6 qt (2.5 L)
Drive axle	2.6 qt (2.5 L)
Vibration system	7.1 qt (6.7 L)

**CAB**

Insulated from chassis by flexible shock absorbers, handrail, dual rearview mirrors, front lighting, instrument panel anti-vandal guard, front and rear windshield with windshield wipers/washers and demisters. Cab door can be fastened in open position (gas strut). Exceptional front/rear visibility. ROPS protection.

**STANDARD EQUIPMENT**

- ROPS & FOPS protection
- Anti-vandal guard
- Hydrostatic drive for both drum and wheels
- Dual amplitude vibration
- Interwheel differential lock
- Articulated chassis
- Front and rear pull points
- 4 point lift and tie down provision
- 14.9 x 24 8PR tires
- Electro-hydraulic platform and hood tilt
- Fan guard
- Alternator guard
- Backup alarm
- Tire ballast for -13°F (-25°C)
- Halogen work lights, 2F/2R
- Auto-vibration control
- Centralized diagnostic access door
- Master disconnect switch
- Spring applied, hydraulic release parking brake
- 3 working speeds plus transport speed selection
- Isolated operators compartment
- Single lever speed/direction control
- Steering wheel spinner knob
- Vinyl suspension swivel seat with foldable armrest
- 2 in (50.8 mm) retractable seat belt
- Lockable tool box
- Cup holder
- Horn
- Emergency stop button
- Anti-slip traction control with high traction drive components (Padfoot version)
- Spin-on fuel, engine oil and hydraulic filters
- LCD monitor

## OPTIONAL EQUIPMENT

Operator's cab with heat and ventilation  
 Air conditioning  
 Rotating beacon  
 Leveling blade with adjustable skid shoes  
 Padfoot drum

Padfoot shell kit for smooth drum  
 Compaction indicator  
 Engine speed indicator  
 Air intake precleaner

3 in (76.2 mm) retractable seat belt  
 Anti-slip traction control with high traction drive components for smooth drum

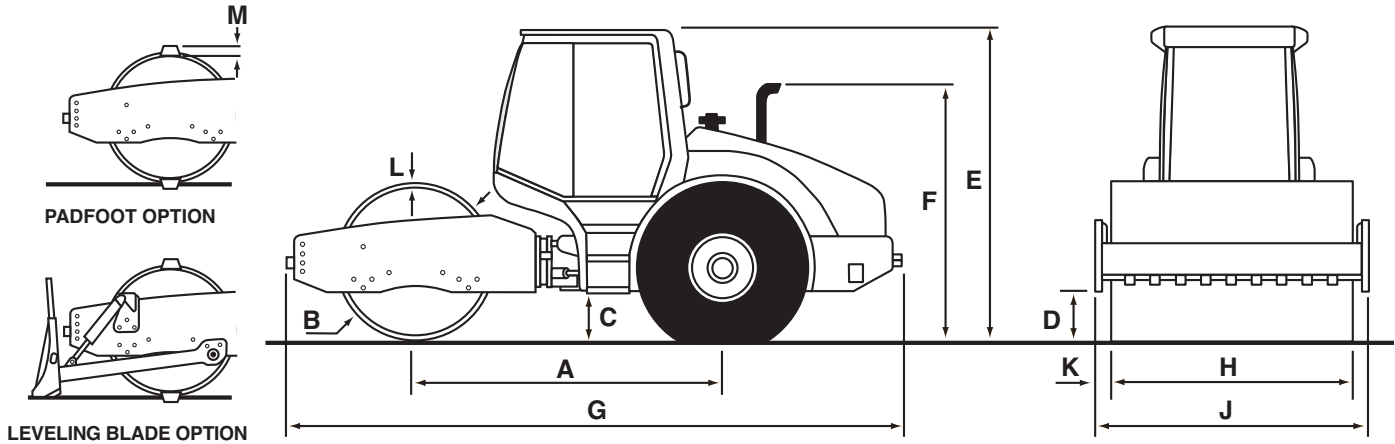

## DIMENSIONS

<b>A.</b>	Wheelbase	101 in (2.6 m)
<b>B.</b>	Drum diameter	51 in (1.3 m)
<b>C.</b>	Ground clearance	15.2 in (0.38 m)
<b>D.</b>	Curb clearance	14.8 in (0.37 m)
<b>E.</b>	Overall height	113 in (2.9 m)
<b>F.</b>	Muffler height	87 in (2.2 m)
<b>G.</b>	Overall length	205 in (5.2 m)
<b>H.</b>	Drum width	66 in (1.7 m)
<b>J.</b>	Overall width	76 in (1.93 m)
<b>K.</b>	Frame extensions	4.7 in (0.12 m)
<b>L.</b>	Drum thickness	1.0 in (0.025 m)
<b>M.</b>	Padfoot height	3.1 in (80 mm)

NOTE: All specifications are stated in accordance with SAE Standards or Recommended Practices, where applicable.

NOTE: All engines meet current EPA emissions requirements.

IMPORTANT: Case Construction Equipment Inc. reserves the right to change these specifications without notice and without incurring any obligation relating to such change. Case Construction Equipment Inc. does not warrant the safety or reliability of attachments from other manufacturers.

Case is a registered trademark of CNH America LLC. Any trademarks referred to herein, in association with goods and/or services of companies other than CNH America LLC, are the property of those respective companies.

**CASE**  
 CONSTRUCTION

[www.casece.com](http://www.casece.com)