

ENGINE

Make	Deutz
Type	D2011 L2 Tier III certified
Rated horsepower	31 hp (23 kW)
Fuel consumption	0.8 gal/hr (3 L/hr)

ELECTRICAL

Voltage	12 volts
Batteries	1
Amp hour	72
Cold cranking amps	640

STEERING

Pump type	Gear
Cylinders	1
Angle (left & right)	33°
Oscillation angle	10°
Inner turning radius	93.7 in (2.38 m)
Relief pressure	2537 PSI (17.5 MPA)

WEIGHT

Operating weight	5,950 lb (2700 kg)
Front drum weight	2,975 lb (1350 kg)
Rear drum weight	2,975 lb (1350 kg)
Front drum linear load	63 lb/in (11.3 kg/cm)
Rear drum linear load	63 lb/in (11.3 kg/cm)

TRAVEL

Drive	Hydrostatic
Variable displacement axial piston type drum drive pump	1
Hydraulic fixed displacement drum drive motors	2
Service brake	Hydrostatic
Parking/emergency brake	Multi-disc
Maximum relief pressure	5075 PSI (35 MPA)
Maximum working speed	4.7 mph (7.5 km/h)
Maximum travel speed	8.5 mph (13.6 km/h)
Gradeability (vibration off)	40%

VIBRATION

Hydraulic circuit type	Closed
Pump type	Gear
Fixed displacement hydraulic motor	2
Maximum relief pressure	3480 PSI (24 MPA)
Vibration	Eccentric
Frequency —	
Low	3180 vpm (53 Hz)
High	3720 vpm (62 Hz)
Rated amplitude	0.0185 in (0.47 mm)
Centrifugal force —	
Low	5,242 lbs (23.8 kN)
High	7,159 lbs (32.5 kN)
Dynamic linear load —	
Low	111 lbs/in (0.02 kN/mm)
High	152 lbs/in (0.03 kN/mm)
Watering system	Pressurized
Front tank capacity	14 gal (53 L)
Rear tank capacity	39.6 gal (150 L)
Tank type	Polyurethane

CAPACITIES

Fuel tank	15.9 gal (60 L)
Engine oil	1.7 gal (6.5 L)
Hydraulic reservoir	10 gal (38 L)
Vibration system (each)	0.48 gal (1.8 L)

OPERATORS COMPARTMENT

Insulated from chassis by flexible shock absorbers, handrail, instrument panel anti-vandal guard, exceptional front/rear visibility, ROPS protection, single lever speed and direction control with vibration on/off control.

MAXIMUM COMPACTED LIFT THICKNESS

Sand/gravel	11.8 in (300 mm)
Mixed soils	7.9 in (200 mm)
Asphalt	4.7 in (120 mm)

STANDARD EQUIPMENT

Fixed ROPS
Anti-vandal guard
Hydrostatic drive for both drums
Dual vibration
Front/dual drum vibration control
Auto vibration stop in neutral
Articulated chassis
Hydraulic oil cooler
Backup alarm
2 in (51 mm) retractable seat belt
Suspension seat with foldable arms
Pressurized water system
Machined tapered edge drums
Vulcollon scrapers, adjustable
2-stage water filtration
Master disconnect switch
Horn
Hourmeter
Emergency stop button
4-point lift and tie down provision
Watering system drains
Electric fuse protection
Steering wheel spinner knob
Spin-on fuel, engine oil and hydraulic filters
Tool box
Flip open hood
Indicator lights
Battery
Engine oil pressure
Intake preheater
Engine temperature
Parking brake
Vibration ON/OFF
Sprinkler system ON/OFF

OPTIONAL EQUIPMENT

Rotating beacon
Halogen work lights
Foldable ROPS
3 in (76 mm) retractable seat belt
Sunshade for fixed ROPS
Brake release

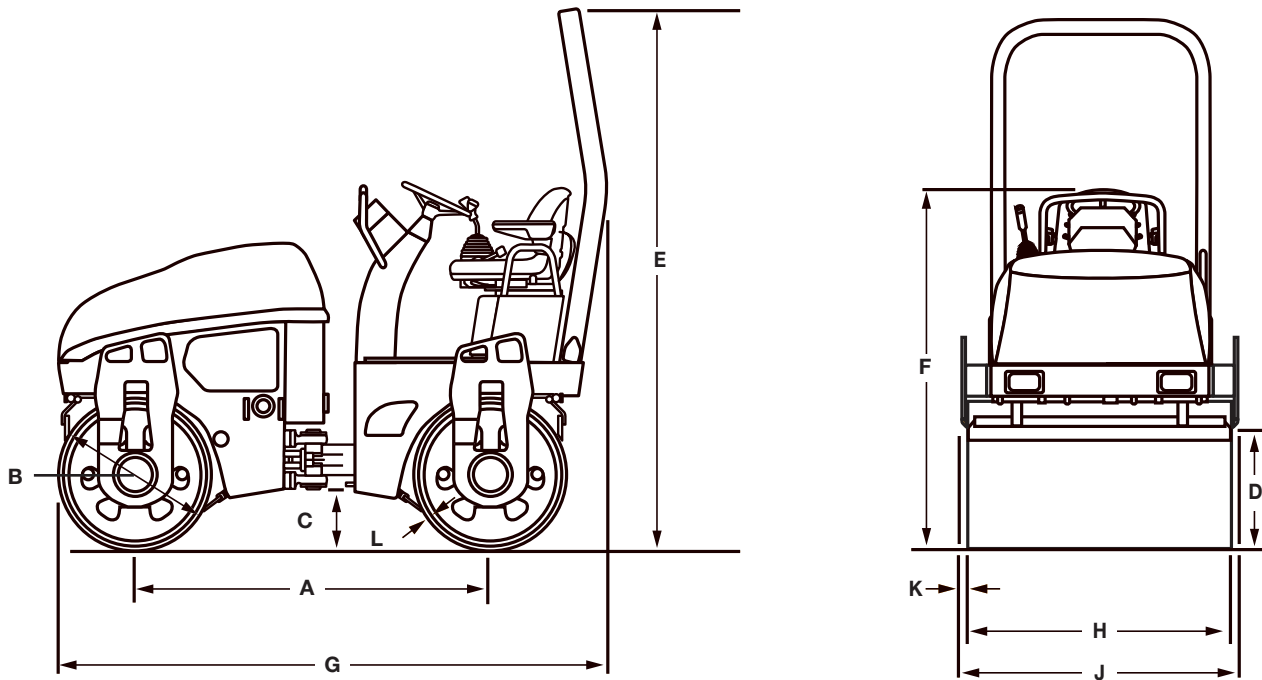

DIMENSIONS

A. Wheelbase	67.6 in (1716 mm)
B. Drum diameter	29 in (740 mm)
C. Ground clearance	12 in (310 mm)
D. Curb clearance	23 in (590 mm)
E. Overall height	105 in (2680 mm)
F. Folded ROPS height	72 in (1825 mm)
G. Overall length	104 in (2640 mm)
H. Drum width	47.2 in (1200 mm)
J. Overall width	50.8 in (1290 mm)
K. Frame extensions	1.8 in (45 mm)
L. Drum thickness	0.5 in (12 mm)

NOTE: All specifications are stated in accordance with SAE Standards or Recommended Practices, where applicable.

NOTE: All engines meet current EPA emissions requirements.

IMPORTANT: CNH America LLC reserves the right to change these specifications without notice and without incurring any obligation relating to such change. CNH America LLC does not warrant the safety or reliability of attachments from other manufacturers.

Case is a registered trademark of CNH America LLC. Any trademarks referred to herein, in association with goods and/or services of companies other than CNH America LLC, are the property of those respective companies.



www.casece.com