

CX330

**EXCAVATOR
TIER III CERTIFIED**

ENGINE

Model	Isuzu AH-6HKIX, Tier III certified
Type	4-stroke, turbocharged
Cylinders	6
Bore/Stroke	4.5 in x 4.9 in (115 x 125 mm)
Displacement	475 in ³ (7790 cc)
Fuel injection	Direct
Fuel injection pump	Electronic
Fuel	Diesel
Cooling	Liquid
Horsepower per SAE J1349	
Net	271 (202 kW) @ 2000 rpm
Maximum torque @ 1500 rpm	
Net	796 lb-ft (1080 N·m)

BOOM/ARM

Boom	
Length	21 ft 2 in (6.45 m)
Boom w/arm cylinder & plumbing	6,982 lb (3167 kg)
Hoist cylinders (2)	761 lb (345 kg) ea
Total weight	8,503 lb (3857 kg)
13 ft 3 in Arm (4.04 m)	
Length	13 ft 3 in (4.04 m)
Bare arm	3,150 lb (1429 kg)
Bucket cylinder linkage & plumbing	1,356 lb (615 kg)
Total weight	4,506 lb (2044 kg)
10 ft 8 in Arm (3.25 m)	
Length	10 ft 8 in (3.25 m)
Bare arm	2,414 lb (1095 kg)
Bucket cylinder linkage & plumbing	1,356 lb (615 kg)
Total weight	3,770 lb (1710 kg)
8 ft 8 in Arm (2.63 m)	
Length	8 ft 8 in (2.63 m)
Bare arm	2,275 lb (1032 kg)
Bucket cylinder linkage & plumbing	1,356 lb (615 kg)
Total weight	3,631 lb (1647 kg)

UNDERCARRIAGE

Number of rollers	
Top, each track	2
Bottom, each track	8
Number of shoes	
Triple grouser – each side	48
Link pitch	8.5 in (215.9 mm)

HYDRAULICS

Pumps (2)	Variable displacement axial piston design
Capacity –	
Maximum	2 x 75 gpm (284 L/min)
System relief pressure –	
Standard	4,975 psi (34.3 MPa)
Power Boost	5,410 psi (37.3 MPa)
Control valves –	
4-spool section for left track travel, boom, bucket and arm	
5-spool section for right track travel, boom, auxiliary, swing and arm	
Boom and arm anti-drift valves	
Pilot control hydraulic system –	
Pump (1)	Gear design
Maximum capacity	8.1 gpm (30.5 L/min)
Relief pressure	566 psi (3.9 MPa)
Swing –	
Motor (1)	Fixed displacement axial piston design
Speed	0-9.6 rpm
Brake	Spring-applied hydraulically released with dual cushion relief
Tail swing radius	11 ft 4 in (3.45 m)
Travel –	
Motor (1)	Two-speed axial piston design
Final drive	Planetary gear reduction
Drawbar pull	60,923 lb (271 kN)
Travel Speeds –	
Auto shift high to low	
	Forward/Reverse
Low	2.0 mph (3.2 km/h)
High	3.4 mph (5.5 km/h)
Travel control valve –	Dual stage relief and counter-balance design

HYDRAULIC CYLINDERS

Boom cylinders (2) –	
Bore diameter	5.7 in (145 mm)
Rod diameter	3.9 in (100 mm)
Stroke	58.9 in (1495 mm)
Arm cylinder (1) –	
Bore diameter	6.7 in (170 mm)
Rod diameter	4.7 in (120 mm)
Stroke	68.8 in (1748 mm)
Bucket cylinder (1) –	
Bore diameter	5.9 in (150 mm)
Rod diameter	4.1 in (105 mm)
Stroke	47.6 in (1210 mm)

ELECTRICAL

Voltage	24 volts, negative ground
Alternator	50 amp
Batteries (2)	Low-maintenance 128 Ah (5 hr rate)

SERVICE CAPACITIES

Hydraulic tank	
Refill capacity	46 gal (175 L)
Total system	92 gal (350 L)
Final drive (per side)	11.6 qt (11 L)
Swing drive	6.3 qt (6.0 L)
Engine	
w/filter change	38.0 qt (36 L)
Fuel	153 gal (580 L)
Radiator	31.7 qt (30 L)

OPERATING WEIGHT

With 10 ft 8 in (3.25 m) arm, 31.5 in (800 mm) track shoes, 2,544 lb (1156 kg) bucket, 165 lb (75 kg) operator, full fuel and standard equipment 78,043 lb (35 400 kg)

LIFT CAPACITIES

13 ft 3 in (4.04 m) Arm Lift capacities calculated using a 2,544 lb (1154 kg) bucket, 16,314 lb (7400 kg) counterweight operating in "Light" Mode.

Load (Lift Point) Height	10 ft (3.05 m)		15 ft (4.57 m)		20 ft (6.1 m)		25 ft (7.62 m)		30 ft (9.14 m)		MAXIMUM REACH			
	END	SIDE	END	SIDE	END	SIDE	END	SIDE	END	SIDE	@	END	SIDE	
+25 ft (7.62 m)												27 ft 7 in (8.4 m)	10,330 lbs* (4685 kg)	10,330 lbs* (4685 kg)
+20 ft (6.1 m)										10,943 lbs* (4964 kg)	10,704 lbs (4855 kg)	31 ft 6 in (9.6 m)	7,566 lbs* (3432 kg)	7,566 lbs* (3432 kg)
+15 ft (4.57 m)							15,591 lbs* (7072 kg)	14,517 lbs (6585 kg)	14,355 lbs* (6511 kg)	10,382 lbs (4709 kg)		33 ft 2 in (10.1 m)	7,670 lbs* (3479 kg)	7,670 lbs* (3479 kg)
+10 ft (3.05 m)			26,749 lbs* (12 133 kg)	26,749 lbs* (12 133 kg)	20,758 lbs* (9416 kg)	19,785 lbs (8974 kg)	17,578 lbs* (7973 kg)	13,686 lbs (6208 kg)	15,680 lbs* (7112 kg)	9,927 lbs (4503 kg)		34 ft 1 in (10.38 m)	8,039 lbs* (3646 kg)	7,766 lbs (3522 kg)
+5 ft (1.52 m)	28,307 lbs* (12 840 kg)	28,307 lbs* (12 840 kg)	33,756 lbs* (15 311 kg)	28,407 lbs (12 885 kg)	24,437 lbs* (11 084 kg)	18,261 lbs (8283 kg)	19,655 lbs* (8915 kg)	12,838 lbs (5823 kg)	15,495 lbs (7028 kg)	9,445 lbs (4284 kg)		34 ft 2 in (10.4 m)	8,711 lbs* (3951 kg)	7,451 lbs (3380 kg)
Ground-line	25,954 lbs* (11 772 kg)	25,954 lbs* (11 772 kg)	38,250 lbs* (17 350 kg)	26,377 lbs (11 964 kg)	27,263 lbs* (12 366 kg)	17,074 lbs (7745 kg)	20,121 lbs (9127 kg)	12,130 lbs (5502 kg)	15,049 lbs (6826 kg)	9,034 lbs (4098 kg)		33 ft 6 in (10.2 m)	9,800 lbs* (4445 kg)	7,476 lbs (3391 kg)
-5 ft (-1.52 m)	32,247 lbs* (14 627 kg)	32,247 lbs* (14 627 kg)	39,780 lbs* (18 044 kg)	25,425 lbs (11 532 kg)	27,976 lbs (12 690 kg)	16,359 lbs (7420 kg)	19,604 lbs (8892 kg)	11,663 lbs (5290 kg)	14,770 lbs (6699 kg)	8,777 lbs (3981 kg)		32 ft 1 in (9.8 m)	11,563 lbs* (5245 kg)	7,890 lbs (3579 kg)
-10 ft (-3.05 m)	41,964 lbs* (19 034 kg)	41,964 lbs* (19 034 kg)	38,724 lbs* (17 565 kg)	25,213 lbs (11 436 kg)	27,676 lbs (12 554 kg)	16,098 lbs (7302 kg)	19,412 lbs (8805 kg)	11,490 lbs (5212 kg)				29 ft 9 in (9.1 m)	14,634 lbs* (6638 kg)	8,867 lbs (4022 kg)
-15 ft (-4.57 m)	50,211 lbs* (22 775 kg)	50,211 lbs* (22 775 kg)	35,007 lbs* (15 879 kg)	25,557 lbs (11 592 kg)	25,992 lbs* (11 790 kg)	16,266 lbs (7378 kg)	19,555 lbs* (8870 kg)	11,684 lbs (5300 kg)				26 ft 3 in (7.9 m)	18,009 lbs* (8169 kg)	10,895 lbs (4942 kg)
-20 ft (6.1 m)	38,185 lbs* (17 320 kg)	38,185 lbs* (17 320 kg)	27,483 lbs* (12 466 kg)	26,502 lbs (12 021 kg)	19,849 lbs* (9003 kg)	16,988 lbs (7706 kg)						21 ft 1 in (6.4 m)	18,294 lbs* (8298 kg)	15,769 lbs (7153 kg)

10 ft 8 in (3.25 m) Arm Lift capacities calculated using a 2,544 lb (1154 kg) bucket, 16,314 lb (7400 kg) counterweight operating in "Light" Mode.

Load (Lift Point) Height	10 ft (3.05 m)		15 ft (4.57 m)		20 ft (6.1 m)		25 ft (7.62 m)		30 ft (9.14 m)		MAXIMUM REACH			
	END	SIDE	END	SIDE	END	SIDE	END	SIDE	END	SIDE	@	END	SIDE	
+25 ft (7.62 m)												24 ft 5 in (7.4 m)	13,915 lbs* (6312 kg)	13,915 lbs* (6312 kg)
+20 ft (6.1 m)							16,400 lbs* (7439 kg)	14,960 lbs (6786 kg)				28 ft 10 in (8.8 m)	10,052 lbs* (4559 kg)	10,052 lbs* (4559 kg)
+15 ft (4.57 m)					20,014 lbs* (9078 kg)	20,014 lbs* (9078 kg)	17,718 lbs* (8037 kg)	14,394 lbs (6529 kg)	12,737 lbs* (5777 kg)	10,390 lbs (4713 kg)		30 ft 8 in (9.3 m)	10,261 lbs* (4645 kg)	9,976 lbs (4525 kg)
+10 ft (3.05 m)	35,063 lbs* (15 904 kg)	35,063 lbs* (15 904 kg)	31,330 lbs* (14 211 kg)	30,474 lbs (13 823 kg)	23,489 lbs* (10 654 kg)	19,492 lbs (8841 kg)	19,532 lbs* (8859 kg)	13,671 lbs (6201 kg)	16,092 lbs* (7299 kg)	10,038 lbs (4553 kg)		31 ft 7 in (9.62 m)	10,851 lbs* (4922 kg)	9,150 lbs (4150 kg)
+5 ft (1.52 m)	17,050 lbs* (7734 kg)	17,050 lbs* (7734 kg)	37,415 lbs* (16 971 kg)	27,930 lbs (12 669 kg)	26,761 lbs* (12 138 kg)	18,203 lbs (8257 kg)	20,984 lbs (9518 kg)	12,962 lbs (5879 kg)	15,684 lbs (7114 kg)	9,662 lbs (4382 kg)		31 ft 8 in (9.65 m)	11,898 lbs* (5397 kg)	8,805 lbs (3994 kg)
Ground-line	24,087 lbs* (10 926 kg)	24,087 lbs* (10 926 kg)	40,353 lbs* (18 304 kg)	26,551 lbs (12 043 kg)	28,925 lbs (13 120 kg)	17,293 lbs (7844 kg)	20,373 lbs (9241 kg)	12,411 lbs (5629 kg)	15,367 lbs (6970 kg)	9,370 lbs (4250 kg)		31 ft 0 in (9.4 m)	13,617 lbs* (6176 kg)	8,900 lbs (4037 kg)
-5 ft (-1.52 m)	34,916 lbs* (15 838 kg)	34,916 lbs* (15 838 kg)	40,338 lbs* (18 297 kg)	26,074 lbs (11 827 kg)	28,436 lbs (12 898 kg)	16,832 lbs (7635 kg)	20,035 lbs (9088 kg)	12,106 lbs (5491 kg)				29 ft 5 in (8.9 m)	15,669 lbs (7107 kg)	9,514 lbs (4315 kg)
-10 ft (-3.05 m)	48,493 lbs* (21 996 kg)	48,493 lbs* (21 996 kg)	37,825 lbs* (17 157 kg)	26,170 lbs (11 870 kg)	28,205 lbs* (12 793 kg)	16,785 lbs (7613 kg)	20,038 lbs (9089 kg)	12,109 lbs (5492 kg)				26 ft 11 in (8.2 m)	18,019 lbs (8173 kg)	10,941 lbs (4963 kg)
-15 ft (-4.57 m)	44,393 lbs* (20 136 kg)	44,393 lbs* (20 136 kg)	32,369 lbs* (14 682 kg)	26,758 lbs (12 137 kg)	24,191 lbs* (10 973 kg)	17,175 lbs (7790 kg)						22 ft 11 in (7.0 m)	20,012 lbs* (9077 kg)	14,118 lbs (6404 kg)
-20 ft (6.1 m)			21,613 lbs* (9803 kg)	21,613 lbs* (9803 kg)								16 ft 8 in (5.1 m)	19,088 lbs* (8658 kg)	19,088 lbs* (8658 kg)

8 ft 8 in (2.63 m) Arm Lift capacities calculated using a 2,544 lb (1154 kg) bucket, 16,314 lb (7400 kg) counterweight operating in "Light" Mode.

Load (Lift Point) Height	10 ft (3.05 m)		15 ft (4.57 m)		20 ft (6.1 m)		25 ft (7.62 m)		30 ft (9.14 m)		MAXIMUM REACH			
	END	SIDE	END	SIDE	END	SIDE	END	SIDE	END	SIDE	@	END	SIDE	
+20 ft (6.1 m)							18,034 lbs* (8180 kg)	14,737 lbs (6684 kg)				27 ft 0 in (8.2 m)	14,722 lbs* (6678 kg)	12,765 lbs* (5790 kg)
+15 ft (4.57 m)					21,926 lbs* (9945 kg)	20,477 lbs (9288 kg)	19,121 lbs* (8673 kg)	14,218 lbs (6449 kg)				29 ft 0 in (8.8 m)	15,004 lbs* (6806 kg)	10,975 lbs (4978 kg)
+10 ft (3.05 m)			34,249 lbs* (15 535 kg)	29,418 lbs (13 344 kg)	25,145 lbs* (11 405 kg)	19,112 lbs (8669 kg)	20,707 lbs* (9392 kg)	13,535 lbs (6139 kg)				29 ft 11 in (9.1 m)	15,852 lbs* (7190 kg)	10,029 lbs (4549 kg)
+5 ft (1.52 m)			39,237 lbs* (17 797 kg)	27,188 lbs (12 332 kg)	27,960 lbs* (12 682 kg)	17,923 lbs (8130 kg)	20,891 lbs (9476 kg)	12,888 lbs (5846 kg)	15,717 lbs (7129 kg)	9,701 lbs (4400 kg)		30 ft 1 in (9.17 m)	15,655 lbs (7101 kg)	9,662 lbs (4382 kg)
Ground-line			40,716 lbs* (18 468 kg)	26,240 lbs (11 902 kg)	28,808 lbs* (13 067 kg)	17,168 lbs (7787 kg)	20,380 lbs (9244 kg)	12,428 lbs (5637 kg)				29 ft 4 in (8.9 m)	16,018 lbs (7266 kg)	9,819 lbs (4454 kg)
-5 ft (-1.52 m)	36,164 lbs* (16 404 kg)	36,164 lbs* (16 404 kg)	39,480 lbs* (17 908 kg)	26,076 lbs (11 828 kg)	28,472 lbs (12 915 kg)	16,876 lbs (7655 kg)	20,176 lbs (9152 kg)	12,244 lbs (5554 kg)				27 ft 8 in (8.4 m)	17,377 lbs (7882 kg)	10,616 lbs (4815 kg)
-10 ft (-3.05 m)	48,416 lbs* (21 961 kg)	48,416 lbs* (21 961 kg)	35,859 lbs* (16 265 kg)	26,408 lbs (11 978 kg)	27,142 lbs* (12 311 kg)	17,010 lbs (7715 kg)						24 ft 11 in (7.6 m)	20,462 lbs (9281 kg)	12,480 lbs (5661 kg)
-15 ft (-4.57 m)	37,846 lbs* (17 167 kg)	37,846 lbs* (17 167 kg)	28,901 lbs* (13 109 kg)	27,265 lbs (12 367 kg)	21,330 lbs* (9675 kg)	17,690 lbs (8024 kg)						20 ft 8 in (6.3 m)	20,311 lbs* (9213 kg)	16,939 lbs (7683 kg)

*Lift capacities do not exceed 75% of the minimum tipping load or 87% of the hydraulic lift capacity. Capacities that are marked with an asterisk are hydraulic limited.

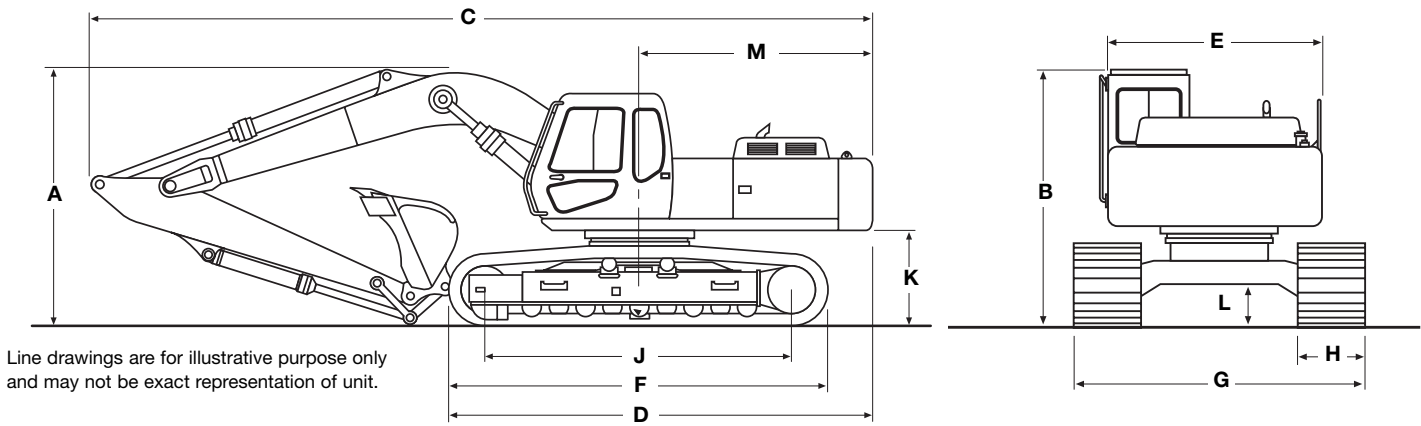

DIMENSIONS

	13 ft 3 in (4.04 m) Arm	10 ft 8 in (3.25 m) Arm	8 ft 8 in (2.63 m) Arm
A. Overall height	11 ft 6 in (3.51 m)	10 ft 10 in (3.29 m)	11 ft 7 in (3.53 m)
B. Cab height	10 ft 1 in (3.07 m)	10 ft 1 in (3.07 m)	10 ft 1 in (3.07 m)
C. Overall length	36 ft 5 in (11.09 m)	36 ft 3 in (11.05 m)	36 ft 6 in (11.13 m)
D. w/o attachment	19 ft 5 in (5.91 m)	19 ft 5 in (5.91 m)	19 ft 5 in (5.91 m)
E. Width of upperstructure	10 ft 0 in (3.04 m)	10 ft 0 in (3.04 m)	10 ft 0 in (3.04 m)
E. Width of upperstructure w/catwalks	11 ft 9 in (3.58 m)	11 ft 9 in (3.58 m)	11 ft 9 in (3.58 m)
F. Track overall length	16 ft 4 in (4.98 m)	16 ft 4 in (4.98 m)	16 ft 4 in (4.98 m)
G. Track overall width w/31.5 in (800 mm) shoes	10 ft 6 in (3.19 m)	10 ft 6 in (3.19 m)	10 ft 6 in (3.19 m)
H. Track shoe width	31.5 in (800 mm)	31.5 in (800 mm)	31.5 in (800 mm)
J. Center to center (idler to sprocket)	13 ft 3 in (4.04 m)	13 ft 3 in (4.04 m)	13 ft 3 in (4.04 m)
K. Upperstructure ground clearance	4 ft 0 in (1.21 m)	4 ft 0 in (1.21 m)	4 ft 0 in (1.21 m)
L. Minimum ground clearance	1 ft 7 in (0.48 m)	1 ft 7 in (0.48 m)	1 ft 7 in (0.48 m)
M. Tail swing radius	11 ft 4 in (3.45 m)	11 ft 4 in (3.45 m)	11 ft 4 in (3.45 m)
Working weight*	78,779 lb (35 734 kg)	78,043 lb (35 400 kg)	77,904 lb (35 337 kg)
Ground pressure	7.4 psi (51 kPa)	7.4 psi (51 kPa)	7.4 psi (51 kPa)

*With 31.5 in (800 mm) track shoe, 2,544 lb (1154 kg) bucket, 165 lb (75 kg) operator, full fuel and standard equipment.

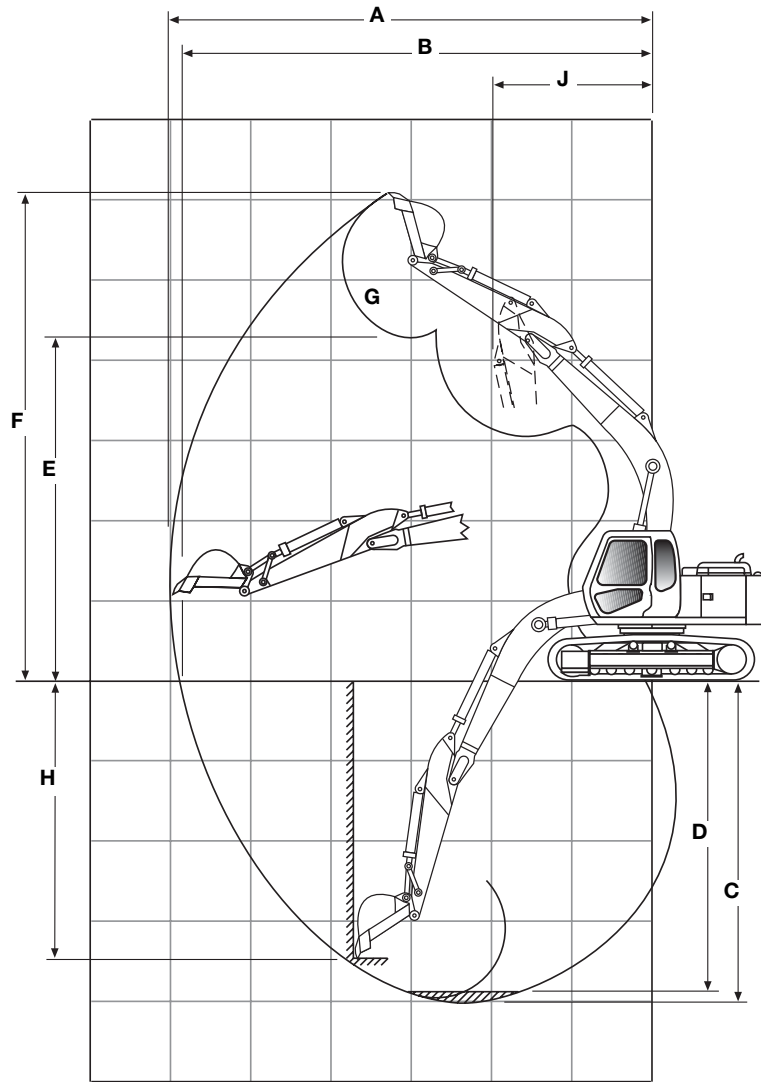

PERFORMANCE SPECS

	13 ft 3 in (4.04 m) Arm	10 ft 8 in (3.25 m) Arm	8 ft 8 in (2.63 m) Arm
A. Maximum dig radius	39 ft 1 in (11.9 m)	36 ft 8 in (11.17 m)	35 ft 0 in (10.67 m)
B. Dig radius at groundline	38 ft 5 in (11.72 m)	36 ft 0 in (10.98 m)	34 ft 4 in (10.47 m)
C. Maximum dig depth	26 ft 8 in (8.14 m)	24 ft 1 in (7.34 m)	22 ft 1 in (6.73 m)
D. Dig depth - 8 ft 0 in (2.44 m) level bottom	26 ft 3 in (8.01 m)	23 ft 7 in (7.19 m)	21 ft 6 in (6.55 m)
E. Dump height	24 ft 9 in (7.54 m)	23 ft 9 in (7.23 m)	23 ft 5 in (7.14 m)
F. Overall reach height	35 ft 0 in (10.67 m)	34 ft 0 in (10.37 m)	33 ft 10 in (10.32 m)
G. Bucket rotation	173°	173°	173°
H. Vertical straight wall dig depth	23 ft 5 in (7.15 m)	20 ft 10 in (6.35 m)	19 ft 7 in (5.97 m)
J. Minimum swing radius	15 ft 0 in (4.56 m)	14 ft 9 in (4.50 m)	15 ft 2 in (4.63 m)
Arm digging force			
Standard	31,586 lb (140.5 kN)	36,846 lb (163.9 kN)	43,838 lb (195.0 kN)
Power Boost	34,306 lb (152.6 kN)	40,016 lb (178.0 kN)	47,435 lb (211.0 kN)
Bucket digging force			
Standard	51,436 lb (228.8 kN)	51,436 lb (228.8 kN)	51,436 lb (228.8 kN)
Power Boost	55,843 lb (248.4 kN)	55,843 lb (248.4 kN)	55,843 lb (248.4 kN)

STANDARD EQUIPMENT

OPERATOR'S COMPARTMENT

Cab with Isomount® system
Adjustable deluxe seat with
3 in (76 mm) retractable seat belt
Front window safety glass
Climate Control System
AM/FM Radio w/auto tuner
Roof hatch, skylight
Sliding Lexan* windows
Windshield wiper w/washer
Anti-theft device

ENGINE

Isuzu AH-6HKIX turbocharged diesel
Tier III certified
Warm up mode
Selectable one touch or auto
accelerator/decelerator
Auto engine derate

ELECTRICAL

Batteries (2)
Electronic Systems Monitor
Horn, dual

HYDRAULICS

ISO pattern pilot controls
4 Position mode selector: H, S, L & Auto
Auto Power Boost
2 Variable flow piston pumps
Auxiliary attachment mode
Neutral pump destroke
Auxiliary hydraulic valve
Boom and arm anti-drift valves
Selectable cushion control for boom and arm
Controlled free swing
Ultra Clean filtration system

UNDERCARRIAGE

Shoes: 31.5 in (800 mm) 3-bar, 48 per side
Track length: 16 ft 4 in (4.98 m)
Track gauge: 8 ft 6 in (2.59 m)
Sealed and lubed track

TRACK DRIVE

2-speed hydrostatic travel
Straight tracking travel priority
Disc-type parking brakes

UPPERSTRUCTURE

Boom: 21 ft 2 in (6.45 m) one piece
Free swing control
Hammer adaptable, no reinforcing required
Swing brake

OTHER

Counterweight: 16,314 lb (7400 kg)
Single key lockup

OPTIONAL EQUIPMENT

UPPERSTRUCTURE

Arm: 13 ft 3 in, 10 ft 8 in or 8 ft 8 in
(4.04 m, 3.25 m or 2.63 m)
Front vandal guard
Front screen 2 in x 2 in
Front guard vertical bars
FOPS – top cab guard

HYDRAULICS

Auxiliary hydraulics
Single acting, one pump
Double acting, single or dual pump (includes
heavy-duty bucket linkage)
Double acting general purpose
for use with thumb kit
Control pattern selector valve

OTHER

Load holding control devices
Cylinder mounted
Case/JRB Slide-Loc* Hydraulic
Coupler

BUCKETS

Application	Width	SAE Heaped Capacity
General purpose	30 in to 60 in (0.76 to 1.52 m)	1.26 yd ³ to 2.93 yd ³ (0.96 m ³ to 2.24 m ³)
Heavy-duty	30 in to 54 in (0.76 to 1.37 m)	1.22 yd ³ to 2.53 yd ³ (0.93 m ³ to 1.93 m ³)
Extreme-duty	30 in to 48 in (0.76 to 1.22 m)	1.12 yd ³ to 2.04 yd ³ (0.86 m ³ to 1.56 m ³)
Heavy-duty cast lip	39 in to 45 in (0.76 to 1.14 m)	1.47 yd ³ to 1.76 yd ³ (1.12 m ³ to 1.35 m ³)
Ditching	72 in (1.83 m)	2.20 yd ³ (1.68 m ³)

This page intentionally left blank.

NOTE: All specifications are stated in accordance with SAE Standards or Recommended Practices, where applicable.

NOTE: All engines meet current EPA emissions requirements.

IMPORTANT: CNH America LLC reserves the right to change these specifications without notice and without incurring any obligation relating to such change. CNH America LLC does not warrant the safety or reliability of attachments from other manufacturers.

Case is a registered trademark of CNH America LLC. Any trademarks referred to herein, in association with goods and/or services of companies other than CNH America LLC, are the property of those respective companies.



www.casece.com

 **CASE IS A BRAND OF CNH.**
A GLOBAL LEADER IN CONSTRUCTION EQUIPMENT, AGRICULTURAL EQUIPMENT AND FINANCIAL SERVICES.

Form No. CCE10240503
Same information as form no. CCE1190544

Printed in U.S.A.

© 2005 CNH America LLC
All Rights Reserved