

CX27B

**COMPACT EXCAVATOR
TIER IV COMPLIANT**

ENGINE

Model	Yanmar 3TNV82-A-SYB Tier IV compliant
Cylinders	3
Bore/Stroke	3.22 in x 3.31 in (82 x 84 mm)
Displacement	81.1 in ³ (1330 cc)
Fuel injection	Direct
Fuel injection pump	Mechanical
Fuel	Diesel
Fuel filter	Full flow, paper element
Cooling	Liquid
Horsepower per SAE J1349	
Net	21.3 hp (15.9 kW) @ 2200 rpm
Maximum torque @ 1320 rpm	
Net	58.3 lb·ft (79.0 N·m)

BOOM/ARM

Boom	
Swing	55° left/60° right
Length	7 ft 3 in (2.2 m)
Boom w/arm cylinder & plumbing	315 lb (142.8 kg)
Arm	
Length	3 ft 8 in (1.12 m)
Arm w/bucket cylinder linkage & plumbing	176 lb (79.8 kg)

UNDERCARRIAGE

Number of rollers	
Top, each track	1
Bottom, each track	4
Gradeability	58% (30°)
Drawbar Pull	6,361 lb (2885 kg)

HYDRAULICS

Pumps	Tandem variable displacement axial piston pump
Capacity –	
Maximum	2 x 7.0 gpm (2 x 26.4 L/min)
Auxiliary Flow	10.8 gpm (40.7 L/min)
System relief pressure –	
Standard	3,336 psi (23.0 MPa)
Pilot control hydraulic system –	
Pump (1)	Gear pump
Maximum capacity	3.2 gpm (12.2 L/min)
Relief pressure	514 psi (3.5 MPa)
Control valves –	
	10 spool
Pilot control for left/right track travel, boom, arm, bucket & swing	
Manual control for auxiliary & backfill blade	
Swing/Dozer blade	
Motor (1)	Fixed displacement axial piston design
Speed	0-8.7 rpm
Brake	Spring applied, hydraulically released with dual cushion relief
Tail swing radius	2 ft 5 in (750 mm)
Tail swing overhang	0 ft 0 in (0 mm)
Travel –	
Motor (2)	Two-speed axial piston design
Final drive	Planetary gear reduction
Travel speeds –	
	Forward/Reverse
Low	1.4 mph (2.3 km/h)
High	2.5 mph (4.1 km/h)

HYDRAULIC CYLINDERS

Boom cylinders (1) –	
Bore diameter	2.76 in (70 mm)
Rod diameter	1.57 in (40 mm)
Stroke	18.5 in (471 mm)
Arm cylinder (1) –	
Bore diameter	2.76 in (70 mm)
Rod diameter	1.57 in (40 mm)
Stroke	19.8 in (502 mm)
Bucket cylinder (1) –	
Bore diameter	2.36 in (60 mm)
Rod diameter	1.18 in (30 mm)
Stroke	16.42 in (417 mm)

ELECTRICAL

Voltage	12 volts, negative ground
Alternator	20 amp
Batteries (1) 12V	Low-maintenance

SERVICE CAPACITIES

Hydraulic tank	
Refill capacity	5.3 gal (20 L)
Total system	6.6 gal (25 L)
Engine	
w/filter change	1.5 gal (5.5 L)
Fuel	7.4 gal (28 L)
Radiator	1.0 gal (3.8 L)

OPERATING WEIGHT

With 165 lb (75 kg) operator, 137 lb (62 kg) bucket, full fuel and standard equipment 5,556 lb (2520 kg)

LIFT CAPACITIES

Canopy model – 3 ft 8 in (1.12 m) Arm *Lift capacities calculated using 9.8 in (250 mm) shoes, 137 lb (62 kg) bucket, blade down.*

Load (Lift Point) Height	5 ft (1.5 m)		7.5 ft (2.3 m)		10 ft (3.0 m)		12.5 ft (3.8 m)	
	END	SIDE	END	SIDE	END	SIDE	END	SIDE
+10 ft (3.0 m)					920 lb 410 kg	920 lb 410 kg		
+7.5 ft (2.3 m)					970 lb 440 kg	910 lb 410 kg		
+5 ft (1.52 m)			1,600 lb 720 kg	1,380 lb 620 kg	1,180 lb 530 kg	870 lb 390 kg	1,020 lb 460 kg	590 lb 270 kg
+2.5 ft (0.8 m)			2,230 lb 1010 kg	1,260 lb 570 kg	1,420 lb 640 kg	810 lb 370 kg	1,100 lb 500 kg	570 lb 260 kg
Ground Level	2,250 lb 1020 kg	2,250 lb 1020 kg	2,450 lb 1110 kg	1,200 lb 540 kg	1,560 lb 710 kg	780 lb 350 kg	1,130 lb 510 kg	550 lb 250 kg
-2.5 ft (-0.8 m)	3,860 lb 1750 kg	2,440 lb 1100 kg	2,300 lb 1040 kg	1,200 lb 540 kg	1,500 lb 680 kg	770 lb 350 kg		
-5 ft (-1.52 m)	2,980 lb 1350 kg	2,510 lb 1130 kg	1,760 lb 800 kg	1,240 lb 560 kg				

*Rated loads are hydraulic limits rather than tipping load limits.

Cab model – 3 ft 8 in (1.12 m) Arm *Lift capacities calculated using 9.8 in (250 mm) shoes, 137 lb (62 kg) bucket, blade down.*

Load (Lift Point) Height	5 ft (1.5 m)		7.5 ft (2.3 m)		10 ft (3.0 m)		12.5 ft (3.8 m)	
	END	SIDE	END	SIDE	END	SIDE	END	SIDE
+10 ft (3.0 m)					920 lb 410 kg	920 lb 410 kg		
+7.5 ft (2.3 m)					970 lb 440 kg	970 lb 440 kg		
+5 ft (1.52 m)			1,600 lb 720 kg	1,490 lb 670 kg	1,180 lb 530 kg	940 lb 420 kg	1,020 lb 460 kg	650 lb 290 kg
+2.5 ft (0.8 m)			2,230 lb 1010 kg	1,360 lb 620 kg	1,420 lb 640 kg	890 lb 400 kg	1,100 lb 500 kg	620 lb 280 kg
Ground Level	2,250 lb 1020 kg	2,250 lb 1020 kg	2,450 lb 1110 kg	1,310 lb 590 kg	1,560 lb 710 kg	850 lb 380 kg	1,130 lb 510 kg	610 lb 270 kg
-2.5 ft (-0.8 m)	3,860 lb 1750 kg	2,640 lb 1200 kg	2,300 lb 1040 kg	1,310 lb 590 kg	1,500 lb 680 kg	850 lb 380 kg		
-5 ft (-1.52 m)	2,980 lb 1350 kg	2,710 lb 1230 kg	1,760 lb 800 kg	1,350 lb 610 kg				

*Rated loads are hydraulic limits rather than tipping load limits.

Canopy model – 4 ft 6 in (1.37 m) Arm *Lift capacities calculated using 9.8 in (250 mm) shoes, 137 lb (62 kg) bucket, blade down.*

Load (Lift Point) Height	5 ft (1.5 m)		7.5 ft (2.3 m)		10 ft (3.0 m)		12.5 ft (3.8 m)	
	END	SIDE	END	SIDE	END	SIDE	END	SIDE
+10 ft (3.0 m)					750 lb 340 kg	750 lb 340 kg		
+7.5 ft (2.3 m)					820 lb 370 kg	820 lb 370 kg	850 lb 380 kg	610 lb 270 kg
+5 ft (1.5 m)			1,330 lb 600 kg	1,300 lb 600 kg	1,040 lb 470 kg	870 lb 390 kg	920 lb 420 kg	580 lb 260 kg
+2.5 ft (0.8 m)			2,030 lb 920 kg	1,260 lb 570 kg	1,320 lb 600 kg	800 lb 360 kg	1,030 lb 470 kg	560 lb 250 kg
Ground Level	2,010 lb 910 kg	2,010 lb 910 kg	2,390 lb 1080 kg	1,190 lb 540 kg	1,510 lb 680 kg	760 lb 340 kg	1,110 lb 500 kg	540 lb 240 kg
-2.5 ft (-0.8 m)	3,250 lb 1470 kg	2,380 lb 1080 kg	2,360 lb 1070 kg	1,170 lb 530 kg	1,520 lb 690 kg	750 lb 340 kg	1040 lb 470 kg	530 lb 240 kg
-5 ft (-1.5 m)	3,520 lb 1590 kg	2,430 lb 1100 kg	1,970 lb 890 kg	1,190 lb 540 kg	1,240 lb 560 kg	760 lb 340 kg		

*Rated loads are hydraulic limits rather than tipping load limits.

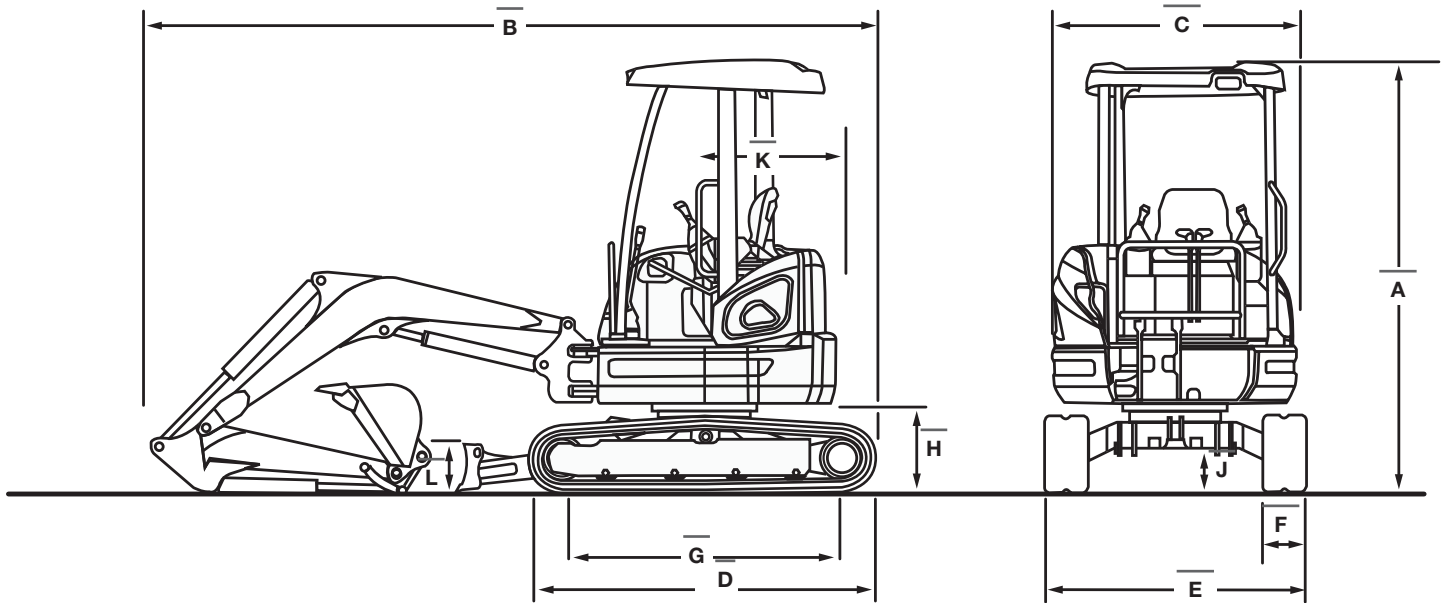

DIMENSIONS

A. Overall height	8 ft 2 in (2.50 m)
B. Overall length	13 ft 11 in (4.13 m)
C. Width of upperstructure	4 ft 7 in (1.40 m)
D. Track overall length	6 ft 6 in (1.98 m)
E. Track overall width w/9.8 in (250 mm) shoes	4 ft 11 in (1.50 m)
F. Track shoe width	9.8 in (250 mm)
G. Center to center (idler to sprocket)	5 ft 3 in (1.59m)
H. Upperstructure ground clearance	1 ft 8 in (520 mm)
J. Minimum ground clearance	9.8 in (250 mm)
K. Tail swing radius	2 ft 5 in (750 mm)
L. Backfill blade height	11.8 in (300 mm)
Working weight	5,556 lb (2520 kg)
Ground pressure	4.06 psi (28 kPa)
Boom swing	Left 60°/ Right 55°
Tail swing overhang	0 ft 0 in (0 m)

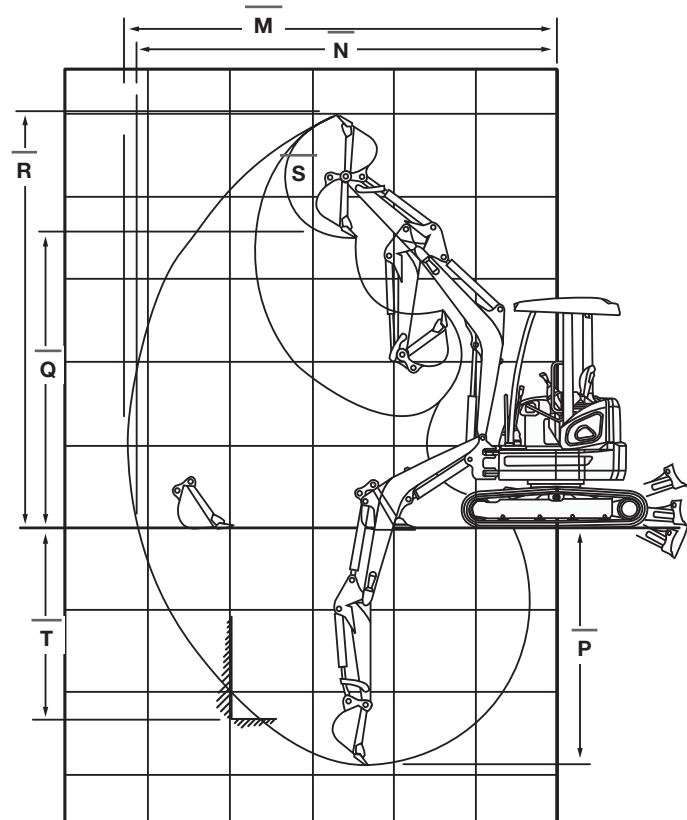

PERFORMANCE SPECS

	4 FT 6 IN (1.37 M) ARM	3 FT 8 IN (1.12 M) ARM
M. Maximum dig radius	16 ft 0 in (4.89 m)	15 ft 3 in (4.64 m)
N. Dig radius at groundline	15 ft 8 in (4.77 m)	14 ft 10 in (4.51 m)
P. Maximum dig depth	9 ft 2 in (2.79 m)	8 ft 4 in (2.54 m)
Q. Dump height	10 ft 5 in (3.17 m)	9 ft 8 in (2.97 m)
R. Overall reach height	14 ft 8 in (4.47 m)	14 ft 0 in (4.26 m)
S. Bucket rotation	178°	178°
T. Vertical straight wall dig depth	8 ft 5 in (2.56 m)	7 ft 7 in (2.32 m)
Arm digging force	2,877 lb (1305 kg)	3,327 lb (1509 kg)
Bucket digging force		
2 Position Bucket	6,351 lb (2881 kg)	6,351 lb (2881 kg)

STANDARD EQUIPMENT

OPERATOR'S COMPARTMENT

ROPS/FOPS three post canopy

Operator's controls:

Pilot operated hand controls and foot pedals

Display includes:

Engine oil pressure, water temperature lamp, air filter lamp, water separator detection lamp, low fuel warning lamp, battery charge lamp, glow plug indicator lamp, water temperature gauge and hourmeter

Adjustable seat with seat belt

Arm rests

ENGINE

Yanmar 3TNV82-A-SYB diesel

4 Cycle

Water cooled

Direct injection

One touch decelerator

Engine access under rear hood

Dry type air cleaner with restriction indicator

Glow plug starting aid

ELECTRICAL

12-volt electrical starting system

Heavy-duty battery

Horn

HYDRAULICS

Auxiliary hydraulics (single/bi-directional) and plumbing to arm

Large hydraulic oil cooler

Control pattern selector valve

TRACK DRIVE

Rubber tracks

2 speed travel

Fully hydrostatic drive system

Sealed and lubricated track rollers

Track tension adjustment (grease type)

Disc type parking brake (auto release and apply)

UPPER STRUCTURE

Zero tail swing

Swing lock

Swing brake

Swing shock valve

OTHER

Hydraulic backfill blade

OPTIONAL EQUIPMENT

OPERATOR'S COMPARTMENT

Cab enclosure with heater

OTHER

Steel tracks

5 ft 3 in (1.59 m) arm

Mechanical coupler

Rigid thumb

Rigid thumb-coupler

BUCKETS

Width	SAE Heaped Capacity	Weight
12 in (305 mm)	1.4 ft ³ (0.039 m ³)	98 lb (44 kg)
18 in (457 mm)	2.2 ft ³ (0.062 m ³)	130 lb (59 kg)
24 in (610 mm)	3.0 ft ³ (0.85 m ³)	155 lb (70 kg)

NOTE: All specifications are stated in accordance with SAE Standards or Recommended Practices, where applicable.

NOTE: All engines meet current EPA emissions requirements.

IMPORTANT: Case Construction Equipment Inc. reserves the right to change these specifications without notice and without incurring any obligation relating to such change. Case Construction Equipment Inc. does not warrant the safety or reliability of attachments from other manufacturers.

Case is a registered trademark of CNH America LLC. Any trademarks referred to herein, in association with goods and/or services of companies other than CNH America LLC, are the property of those respective companies.



www.casece.com