

ENGINE

Model	Isuzu 4JJ1X, Tier III certified
Type	4-stroke, turbocharged and aftercooled
Cylinders	4
Bore/Stroke	3.76 in x 413 in (95.4 x 104.9 mm)
Displacement	183 in ³ (3.0 L)
Fuel injection	Electronic
Fuel	Diesel
Cooling	Liquid
Horsepower per SAE J1349	
Net	95 hp (71 kW) @ 2000 rpm
Maximum torque @ 1600 rpm	
Net	265 lb-ft (359 N·m)

BOOM/ARM

Boom	
Length	15 ft 2 in (4.63 m)
Boom w/arm cylinder & plumbing	2,002 lb (908 kg)
Hoist cylinders	238 lb (108 kg) ea
Total boom	2,478 lb (1124 kg)

9 ft 11 in Arm (3.01 m)

Bare arm	888 lb (403 kg)
Bucket cylinder linkage & plumbing	469 lb (213 kg)
Total arm weight	1,357 lb (615 kg)

8 ft 2 in Arm (2.5 m)

Bare arm	747 lb (339 kg)
Bucket cylinder linkage & plumbing	469 lb (213 kg)
Total arm weight	1,216 lb (552 kg)

UNDERCARRIAGE

Number of top rollers	
Top, each track	1
Bottom, each track	7
Number of shoes	
Triple grouser – each track	43
Link pitch	6.75 in (171 mm)
Gradability	70%

HYDRAULICS

Pumps (2)	Variable displacement axial piston design
Capacity –	
Maximum	2 x 34.1 gpm (2 x 129 L/min)
System relief pressure –	
Standard	4,975 psi (34.3 MPa)
Power Boost	5,265 psi (36.3 MPa)
Control valves –	
5-spool section for left track travel, auxiliary, swing, arm and boom #2	
4-spool section for right track travel, boom, bucket and arm #2	
Boom and arm anti-drift valves	
Pilot control hydraulic system –	
Pump (1)	Gear design
Maximum capacity	5.8 gpm (22.0 L/min)
Relief pressure	566 psi (3.9 MPa)
Swing –	
Motor (1)	Fixed displacement axial piston design
Speed	0-14.3 rpm
Brake	Spring-applied mechanical disc
Travel –	
Motor (2)	Two-speed axial piston design
Final drive	Planetary gear reduction
Drawbar pull	25,853 lb (115 kN)
Travel Speeds –	
Auto shift high to low	
	Forward/Reverse
Low	2.1 mph (3.4 km/h)
High	3.5 mph (5.6 km/h)
Travel control valve –	
Dual stage relief and counter- balance design with disc-type brakes	

HYDRAULIC CYLINDERS

Boom cylinders (2) –	
Bore diameter	4.1 in (105 mm)
Rod diameter	2.8 in (70 mm)
Stroke	37.8 in (9.61 mm)
Arm cylinder (1) –	
Bore diameter	4.5 in (115 mm)
Rod diameter	3.1 in (80 mm)
Stroke	43.6 in (1108 mm)
Bucket cylinder (1) –	
Bore diameter	3.7 in (95 mm)
Rod diameter	2.6 in (65 mm)
Stroke	34.7 in (881 mm)

ELECTRICAL

Voltage	24 volts, negative ground
Alternator	50 amp
Batteries (2)	Low-maintenance 72 Ah (5 hr rate)

SERVICE CAPACITIES

Hydraulic tank	
Refill capacity	22 gal (82 L)
Total system	41 gal (157 L)
Final drive (per side)	2.2 qt (2.1 L)
Swing drive	2.3 qt (2.2 L)
Engine	
w/filter change	18 qt (17 L)
Fuel	69 gal (260 L)
Radiator	15.6 qt (14.8 L)

OPERATING WEIGHT

With 8 ft 2 in (2.5 m) arm, 23.6 in (600 mm) track shoes, 860 lb (390 kg) bucket, 165 lb (75 kg) operator, full fuel and standard equipment	
27,800 lb (12 610 kg)	
Standard plus dozer blade	
29,500 lb (13 300 kg)	

LIFT CAPACITIES

9 ft 11 in (3.01 m) Arm Lift capacities calculated using a 860 lb (390 kg) bucket and 5,049 lb (2290 kg) counterweight.

Load (Lift Point) Height	5 ft (1.52 m)		10 ft (3.05 m)		15 ft (4.57 m)		20 ft (6.1 m)		25 ft (7.62 m)		MAXIMUM REACH			
	END	SIDE	END	SIDE	END	SIDE	END	SIDE	END	SIDE	@	END	SIDE	
+25 ft (7.62 m)												19 ft 3 in (5.86 m)	3,202 lb* (1452 kg)*	3,202 lb* (1452 kg)*
+20 ft (6.1 m)												23 ft 9 in (7.23 m)	2,802 lb* (1271 kg)*	2,802 lb* (1271 kg)*
+15 ft (4.57 m)							5,602 lb* (2541 kg)*	4,415 lb (2003 kg)				26 ft 4 in (8.02 m)	2,652 lb* (1203 kg)*	2,515 lb (1141 kg)
+10 ft (3.05)					6,902 lb* (3131 kg)*	6,865 lb (3114 kg)	5,965 lb (2706 kg)	4,215 lb (1912 kg)	3,915 lb (1776 kg)	2,715 lb (1232 kg)		27 ft 8 in (8.43 m)	2,652 lb* (1203 kg)*	2,215 lb (1005 kg)
+5 ft (1.52 m)			14,202 lb* (6442 kg)*	12,315 lb (5586 kg)	9,165 lb (4157 kg)	6365 lb (2887 kg)	5,665 lb (2570 kg)	3,965 lb (1799 kg)	3,815 lb (1731 kg)	2,615 lb (1186 kg)		27 ft 11 in (8.50 m)	2,802 lb* (1271 kg)*	2,115 lb (959 kg)
Ground- line	6,002 lb* (2722 kg)*	6,002 lb* (2722 kg)*	17,215 lb (7809 kg)	10,965 lb (4974 kg)	8,565 lb (3885 kg)	5,815 lb (2638 kg)	5,365 lb (2434 kg)	3,665 lb (1663 kg)	3,715 lb (1685 kg)	2,515 lb (1141 kg)		27 ft 1 in (8.25 m)	3,152 lb* (1430 kg)*	2,165 lb (982 kg)
-5 ft (-1.52 m)	10,552 lb* (4786 kg)*	10,552 lb* (4786 kg)*	16,765 lb (7605 kg)	10,615 lb (4815 kg)	8,215 lb (3726 kg)	5,565 lb (2524 kg)	5,215 lb (2366 kg)	3,515 lb (1594 kg)				25 ft 2 in (7.67 m)	3,665 lb (1663 kg)	2,465 lb (1118 kg)
-10 ft (-3.05 m)	15,302 lb* (6941 kg)*	15,302 lb* (6941 kg)*	16,915 lb (7673 kg)	10,715 lb (4860 kg)	8,215 lb (3726 kg)	5,515 lb (2502 kg)	5,215 lb (2366 kg)	3,515 lb (1594 kg)				21 ft 8 in (6.60 m)	4,715 lb (2139 kg)	3,215 lb (1458 kg)
-15 ft (-4.57 m)	24,202 lb* (10 978 kg)*	24,202 lb* (10 978 kg)*	15,652 lb* (7099 kg)*	11,065 lb (5019 kg)	8,415 lb (3817 kg)	5,715 lb (2592 kg)								

8 ft 2 in (2.5 m) Arm Lift capacities calculated using a 860 lb (390 kg) bucket and 5,049 lb (2290 kg) counterweight.

Load (Lift Point) Height	5 ft (1.52 m)		10 ft (3.05 m)		15 ft (4.57 m)		20 ft (6.1 m)		MAXIMUM REACH			
	END	SIDE	END	SIDE	END	SIDE	END	SIDE	@	END	SIDE	
+25 ft (7.62 m)										16 ft 8 in (5.08 m)	3,467 lb* (1572 kg)*	3,467 lb* (1572 kg)*
+20 ft (6.1 m)										21 ft 11 in (6.68 m)	2,967 lb* (1346 kg)*	2,967 lb* (1346 kg)*
+15 ft (4.57 m)					6,217 lb* (2820 kg)*	6,217 lb* (2820 kg)*	6,064 lb (2751 kg)	4,314 lb (1957 kg)		24 ft 9 in (7.54 m)	2,767 lb* (1255 kg)*	2,767 lb* (1255 kg)*
+10 ft (3.05)			10,167 lb* (4611 kg)*	10,167 lb* (4611 kg)*	8,017 lb* (3636 kg)*	6,864 lb (3114 kg)	5,914 lb (2683 kg)	4,214 lb (1912 kg)		26 ft 2 in (7.97 m)	2,767 lb* (1255 kg)*	2,514 lb (1140 kg)
+5 ft (1.52 m)			16,667 lb* (7560 kg)*	11,914 lb (5404 kg)	9,064 lb (4111 kg)	6,314 lb (2864 kg)	5,664 lb (2569 kg)	3,964 lb (1798 kg)		26 ft 5 in (8.05 m)	2,917 lb* (1323 kg)*	2,414 lb (1095 kg)
Ground- line	5,917 lb* (2684 kg)*	5,917 lb* (2684 kg)*	17,114 lb (7763 kg)	10,914 lb (4951 kg)	8,564 lb (3885 kg)	5,864 lb (2660 kg)	5,414 lb (2456 kg)	3,764 lb (1707 kg)		25 ft 6 in (7.77 m)	3,267 lb* (1482 kg)*	2,514 lb (1140 kg)
-5 ft (-1.52 m)	11,367 lb* (5156 kg)*	11,367 lb* (5156 kg)*	17,014 lb (7718 kg)	10,814 lb (4905 kg)	8,364 lb (3794 kg)	5,664 lb (2569 kg)	5,314 lb (2411 kg)	3,614 lb (1639 kg)		23 ft 5 in (7.13 m)	3,917 lb* (1777 kg)*	2,864 lb (1299 kg)
-10 ft (-3.05 m)	18,067 lb* (8195 kg)*	18,067 lb* (8195 kg)*	17,214 lb (7808 kg)	11,014 lb (4996 kg)	8,364 lb (3794 kg)	5,664 lb (2569 kg)	5,364 lb (2433 kg)	3,714 lb (1685 kg)		19 ft 6 in (5.94 m)	5,317 lb* (2412 kg)*	3,964 lb (1798 kg)
-15 ft (-4.57 m)			13,717 lb* (6222 kg)*	11,464 lb (5200 kg)	8,217 lb* (3727 kg)*	6,014 lb (2728 kg)						

NOTE: *Lift capacities do not exceed 75% of the minimum tipping load or 87% of the hydraulic lift capacity.
Capacities that are marked with an asterisk are hydraulic limited.

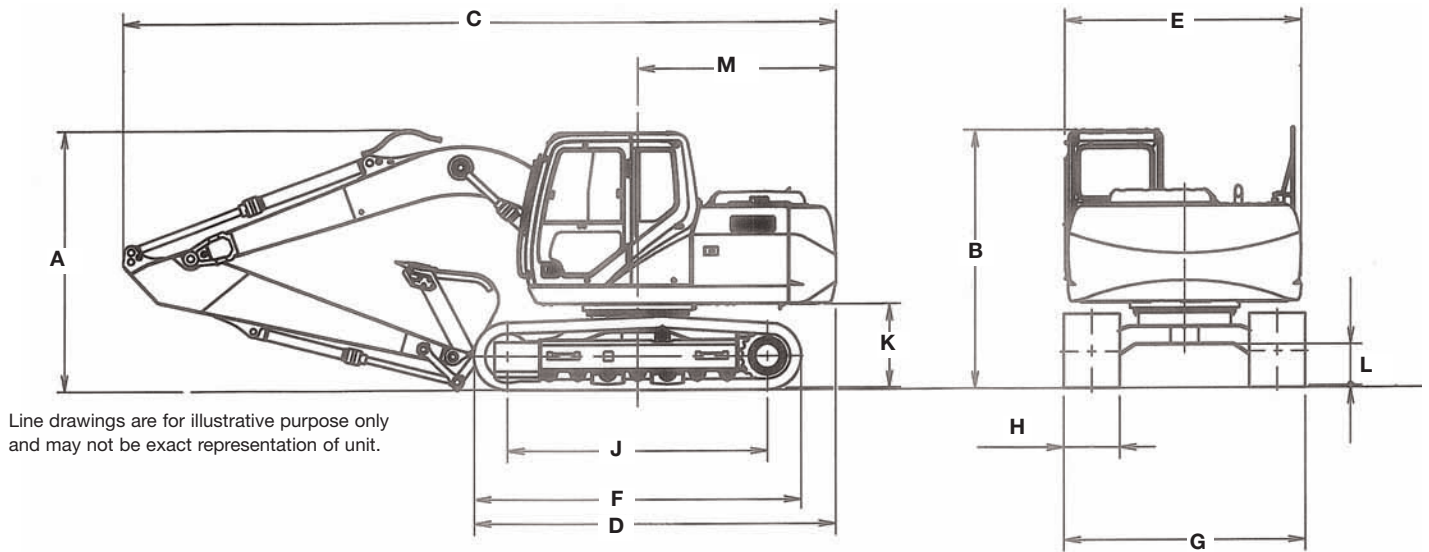

DIMENSIONS

	9 ft 11 in (3.01 m) Arm	8 ft 2 in (2.5 m) Arm
A. Overall height	9 ft 3 in (2.82 m)	9 ft 3 in (2.82 m)
B. Cab height	9 ft 2 in (2.79 m)	9 ft 2 in (2.79 m)
C. Overall length	25 ft 1 in (7.64 m)	25 ft 0 in (7.62 m)
D. w/o attachment	11 ft 9 in (3.58 m)	11 ft 9 in (3.58 m)
E. Width of upperstructure	8 ft 4 in (2.54 m)	8 ft 4 in (2.54 m)
F. Track overall length	11 ft 6 in (3.51 m)	11 ft 6 in (3.51 m)
G. Track overall width w/23.6 in (600 mm) shoes	8 ft 6 in (2.59 m)	8 ft 6 in (2.59 m)
H. Track shoe width	23.6 in (600 mm)	23.6 in (600 mm)
J. Center to center (idler to sprocket)	9 ft 2 in (2.79 m)	9 ft 2 in (2.79 m)
K. Upperstructure ground clearance	2 ft 11 in (890 mm)	2 ft 11 in (890 mm)
L. Minimum ground clearance	1 ft 5 in (432 mm)	1 ft 5 in (432 mm)
M. Tail swing radius	7 ft 0 in (2.13 m)	7 ft 0 in (2.13 m)
Working weight*	27,941 lb (12 674 kg)	27,800 lb (12 610kg)
Ground pressure	5.0 psi (34 kPa)	5.0 psi (34 kPa)

*With 23.6 in (600 mm) track shoe, 884 lb (401 kg) bucket, 165 lb (75 kg) operator, full fuel and standard equipment.

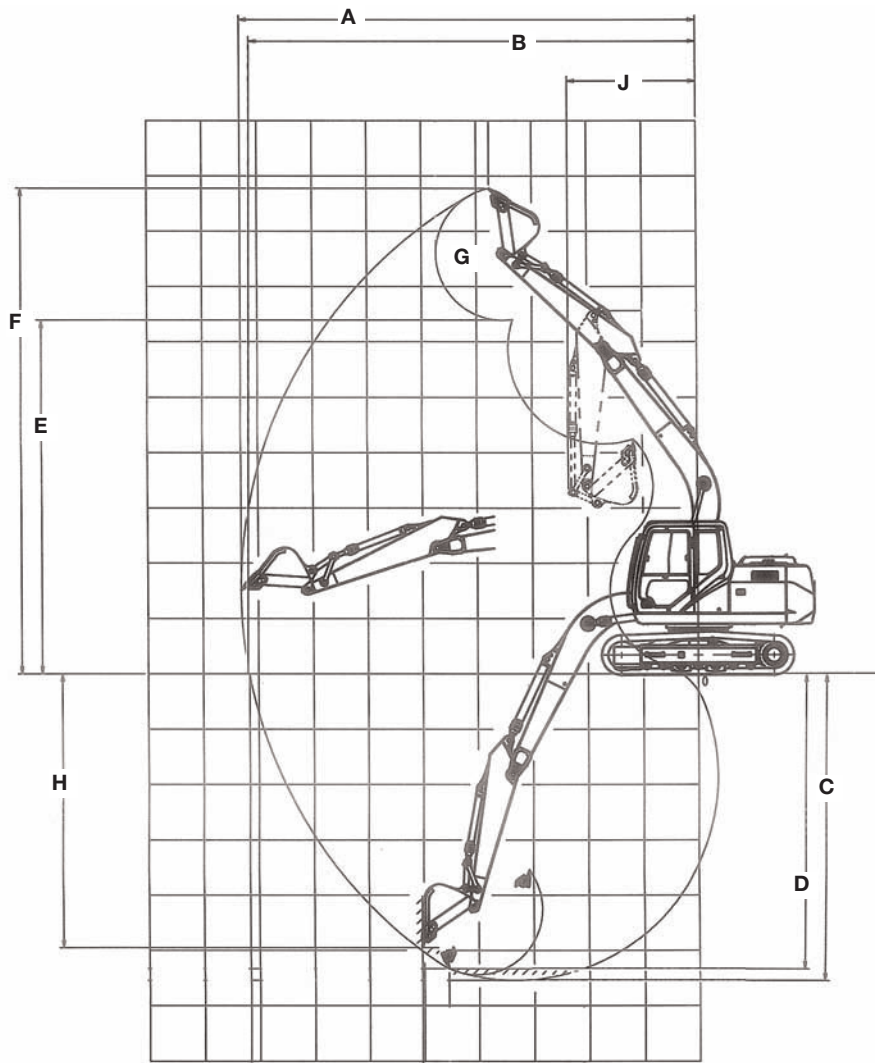

PERFORMANCE SPECS

	9 ft 11 in (3.01 m) Arm	8 ft 2 in (2.5 m) Arm
A. Maximum dig radius	28 ft 9 in (8.77 m)	27 ft 3 in (8.31 m)
B. Dig radius at groundline	28 ft 4 in (8.64 m)	26 ft 10 in (8.17 m)
C. Maximum dig depth	19 ft 10 in (6.05 m)	18 ft 2 in (5.54 m)
D. Dig depth - 8 ft 0 in (2.44 m) level bottom	19 ft 3 in (5.87 m)	17 ft 6 in (5.34 m)
E. Dump height	21 ft 11 in (6.68 m)	21 ft 0 in (6.39 m)
F. Overall reach height	29 ft 8 in (9.05 m)	28 ft 9 in (8.77 m)
G. Bucket rotation	178°	178°
H. Vertical straight wall dig depth	17 ft 7 in (5.35 m)	16 ft 3 in (4.96 m)
J. Minimum swing radius	8 ft 9 in (2.66 m)	7 ft 8 in (2.34 m)
Arm digging force		
Standard	12,589 lb (56.0 kN)	13,938 lb (62.0 kN)
Power Boost	13,489 lb (60.0 kN)	14,837 lb (66.0 kN)
Bucket digging force		
Standard	20,233 lb (90.0 kN)	20,233 lb (90.0 kN)
Power Boost	21,357 lb (95.0 kN)	21,357 lb (95.0 kN)

STANDARD EQUIPMENT

OPERATOR'S COMPARTMENT

Sliding front window - storable
 LCD monitor display
 Skylight
 Cab with Isomount® system
 Adjustable deluxe seat with 3 in (76 mm) retractable seat belt
 Safety glass - all windows
 Climate Control System
 AM/FM Radio w/auto tuner
 Windshield wiper w/washer
 Anti-theft device
 Dome light
 12 volt power supply
 24 volt power supply

ENGINE

Isuzu 4JJ1X turbocharged diesel
 Tier III certified
 Warm up mode
 Selectable one touch or auto accelerator/decelerator
 Dial type throttle control
 Emergency stop
 Auto engine derate

ELECTRICAL

Batteries (2)
 Electronic Systems Monitor
 Boom worklight
 Turntable worklight

HYDRAULICS

ISO pattern pilot controls
 Work mode selector: SP, H & Auto
 Auxiliary attachment mode
 Power Boost - Automatic
 2 Variable flow piston pumps
 Auto pump destroke
 Auxiliary hydraulic valve
 Boom and arm anti-drift valve
 Attachment cushion control for boom and arm
 100% return oil filtration

UNDERCARRIAGE

Shoes: 23.6 in (600 mm) 3-bar, 43 per side
 Track length: 11 ft 6 in (3.51 m)
 Track gauge: 6 ft 6 in (1.98 m)
 Sealed and lubed track

TRACK DRIVE

2-speed hydrostatic travel
 Disc-type parking brakes

UPPERSTRUCTURE

Boom: 15 ft 2 in (3.01 m) one piece
 Hammer adaptable
 Swing brake

OTHER

Counterweight: 5,049 lb (2290 kg)
 Single key lockup

OPTIONAL EQUIPMENT

UPPERSTRUCTURE

Arm: 9 ft 11 in or 8 ft 2 in (3.01 m or 2.5 m)
 FOPS guard level 2
 Front screen
 Front grill
 Vandal guard
 Sun visor
 Rain deflector
 See through skylight

HYDRAULICS

Auxiliary hydraulics
 Single acting, one pump
 Double acting, single or dual pump (includes heavy-duty bucket linkage)
 Double acting general purpose for use with thumb kit
 Control pattern selector valve

OTHER

Air suspension seat
 28 in (700 mm) track shoes
 Rubber link track
 Dozer blade
 Load holding control devices
 Cylinder mounted
 Esco* hydraulic coupler

BUCKETS

Application	Width	SAE Heaped Capacity
General Purpose	24 in thru 42 in (0.61 m thru 1.07 m)	0.50 yd ³ thru 1.00 yd ³ (0.38 m ³ thru 0.76 m ³)
Heavy-duty	24 in thru 42 in (0.61 m thru 1.07 m)	0.50 yd ³ thru 0.88 yd ³ (0.38 m ³ thru 0.67 m ³)
Ditching	60 in or 66 in (1.52 m or 1.68 m)	0.88 yd ³ thru 1.00 yd ³ (0.67 m ³ thru 0.76 m ³)

This page intentionally left blank.

NOTE: All specifications are stated in accordance with SAE Standards or Recommended Practices, where applicable.

NOTE: All engines meet current EPA emissions requirements.

IMPORTANT: Case Construction Equipment Inc. reserves the right to change these specifications without notice and without incurring any obligation relating to such change. Case Construction Equipment Inc. does not warrant the safety or reliability of attachments from other manufacturers.

Case is a registered trademark of CNH America LLC. Any trademarks referred to herein, in association with goods and/or services of companies other than CNH America LLC, are the property of those respective companies.



www.casece.com