

850K

**XLT/WT/LGP
SERIES 2 CRAWLER DOZER
TIER II CERTIFIED**

ENGINE

Model	
Case Family III 668T/M2 diesel, Tier II certified	
Cylinders	6
Bore/Stroke	4.1 in x 5.2 in (104 x 132 mm)
Displacement	411 in ³ (6.8 L)
Fuel injection	Direct
Fuel	#2 Diesel
Fuel filter	Spin-on with in-line strainer
Air intake	Cross-flow
Cooling	Liquid
Engine speeds (rpm)	
High idle - no load	2220±50
Rated - full load	2000
Low idle	800-1050
Horsepower per SAE J1349	
Net	96 (72 kW) @ 2000 rpm
Gross	99 (74 kW) @ 2000 rpm
Peak torque @ 1200 rpm	
Net	321 lb-ft (435 N-m)
Gross	325 lb-ft (441 N-m)
Engine lubrication -	
Pump	Deep sump plate cooler with pressurized under-piston nozzles
Pump operating angle ratings	
Side-to-side	40°
Fore and aft	45°
Oil filtration	Replaceable, spin-on full-flow cartridge

ENGINE COOLING

Radiator -	
Core size area	486 in ² (0.31 m ²)
Rows of tubes	6
Fan -	
Diameter	21.6 in (550 mm)
Ratio	1.1:1

ELECTRICAL SYSTEM

Alternator	
	65 amp 95 amp w/A/C
Battery	
	12-volt low-maintenance 650 cold-cranking amps @ 0° F (-18 C)

POWERTRAIN

Dual path hydrostatic	
Pump - variable axial piston	
Motor - variable bent axis piston	
Maximum drawbar pull*	42,000 lb (186.8 kN)
Transmission	
Single lever control - electronic straight tracking	
Oil filter	2 micron, spin-on replaceable
Travel speeds* -	
Forward	0-6 mph (0-9.7 km/h)
Reverse	0-6 mph (0-9.7 km/h)
*Measured using standard track chain. Increase travel speeds by 4% and reduce drawbar pull by 4% with the optional CELT track chain.	
Parking brakes	
Heavy-duty, spring-applied, hydraulic pressure release	
Steering brakes	
Hydrostatic	
Final drive	2 helical gear reduction to planetary output
Ratio	62:1

TRANSMISSION COOLING

Type	Oil to water
Core size	185.5 in ² (1197 cm ²)

HYDRAULIC SYSTEM

Standard equipment pump	
Pump flow @ 2000 rpm @ 3000 psi (209 kPa)	23.9 gpm (90.5 L/min)
Max. system pressure	3025±75 psi (20 855±515 kPa)

CYLINDERS

Lift cylinder (2)	
Bore diameter	3.50 in (89 mm)
Rod diameter	1.75 in (44.5 mm)
Stroke	15.5 in (394 mm)
Angle cylinder (2)	
Bore diameter	3.50 in (89 mm)
Rod diameter	1.75 in (44.5 mm)
Stroke	15.5 in (394 mm)
Tilt cylinder (1)	
Bore diameter	3.50 in (89 mm)
Rod diameter	1.75 in (44.5 mm)
Stroke	5.80 in (144 mm)

UNDERCARRIAGE

Track adjustment	Hydraulic
Frame	Rigid suspension
Length of track on ground	
	93 in (2352 mm)
Track link pitch	6.73 in (171 mm)
Track shoe height	2.06 in (52 mm)
Pin diameter	1.32 in (33 mm)
Bushing diameter -	
CLT track	2.24 in (57 mm)
CELT track	3.0 in (76 mm)
Bolt diameter	0.625 in (16 mm)
Track shoes per side	40
Track rollers per side	7
Carrier rollers per side	1
Track roller rail dia.	7.48 in (190 mm)

TRACK ON GROUND

Shoe	Area - in ² (cm ²)
18 in (457 mm)	3334 (21 510)
20 in (508 mm)	3704 (23 897)
24 in (610 mm)	4449 (28 703)
28 in (711 mm)	5186 (33 458)

TRACK

Extra Long Track	
18 in (457 mm) closed grousers and CLT	
18 in (457 mm) open grousers and CELT	
Wide Track	
18 in (457 mm) closed grousers and CLT	
18 in (457 mm) open grousers and CELT	
20 in (645 mm) closed grousers and CLT	
20 in (645 mm) open grousers and CELT	
24 in (610 mm) closed grousers and CLT	
24 in (610 mm) open grousers and CELT	
LGP	
28 in (711 mm) closed grousers and CLT	
28 in (711 mm) open grousers and CELT	

OPERATOR ENVIRONMENT

ROPS canopy
Single lever control for speed, steering and direction
Forward/reverse speed ration selector
Adjustable armrests
Foot rests
Retractable seat belt, 2 in (51 mm)
Vinyl suspension seat w/back adjustment

INSTRUMENTATION

Warning lights:
Air filter
Alternator
Engine oil pressure
Hi range
Hydraulic filter
Transmission filter
Transmission pressure
Gauges:
Battery voltage
Fuel level
Hourmeter
Tachometer
Transmission oil temperature
Water temperature
Audible warnings:
Engine oil pressure
Transmission pressure

BLADE

Variable blade pitch	52° forward 60° rearward
Lift speed (per second)	18 in (457 mm)
Cutting edge	Reversible and replaceable
Width	8.0 in (203 mm)
Thickness	0.75 in (19 mm)

RIPPER

Max. penetration	14 in (356 mm)
Width	72.4 in (1839 mm)
Cut width	70.1 in (1780 mm)
Max. ground clearance	17.3 in (439 mm)
Points	Replaceable
Max. number of shanks	5
Tooth spacing –	
with 5 teeth	17.8 in (452 mm)
with 3 teeth	34 in (864 mm)
Hydraulic cylinder (double-acting)	
Diameter	3.25 in (82.6 mm)
Stroke	8.4 in (213 mm)
Rod	1.75 in (44.5 mm)

SERVICE CAPACITIES

Fuel tank	50 gal (189.3 L)
Engine oil w/filter	15.8 qt (15 L)
Engine oil w/o filter	15 qt (14.2 L)
Engine cooling system	20 qt (18.9 L)
Hydraulic reservoir	20 gal (70.7 L)
Final drive (per side)	15 qt (14.2 L)
Track rollers (ea.)	0.26 qt (0.25 L)
Front idlers (ea.)	0.52 qt (0.49 L)
Carrier rollers (ea.)	0.25 qt (0.24 L)

OPERATING WEIGHTS

Unit equipped with ROPS, full fuel tank, 170 lb (77 kg) operator, drawbar, side shield, track guides, backup alarm, horn and lights.

Long Track	19,600 lb (8900 kg)
Wide Track	20,200 lb (9181 kg)
LGP	20,700 lb (9402 kg)

Add-on weights –

Drawbar	85 lb (38 kg)
Ripper (3 shank)	1,400 lb (646 kg)
Winch	1,200 lb (545 kg)
Front counterweight	877 lb (398 kg)
Rear counterweight	900 lb (408 kg)
Cab	930 lb (422 kg)
ROPS heater	70 lb (32 kg)
CELT chain	115 lb (52 kg)
Center rockguard	160 lb (72 kg)
Sweeps	100 lb (47 kg)
Dual batteries	60 lb (29 kg)

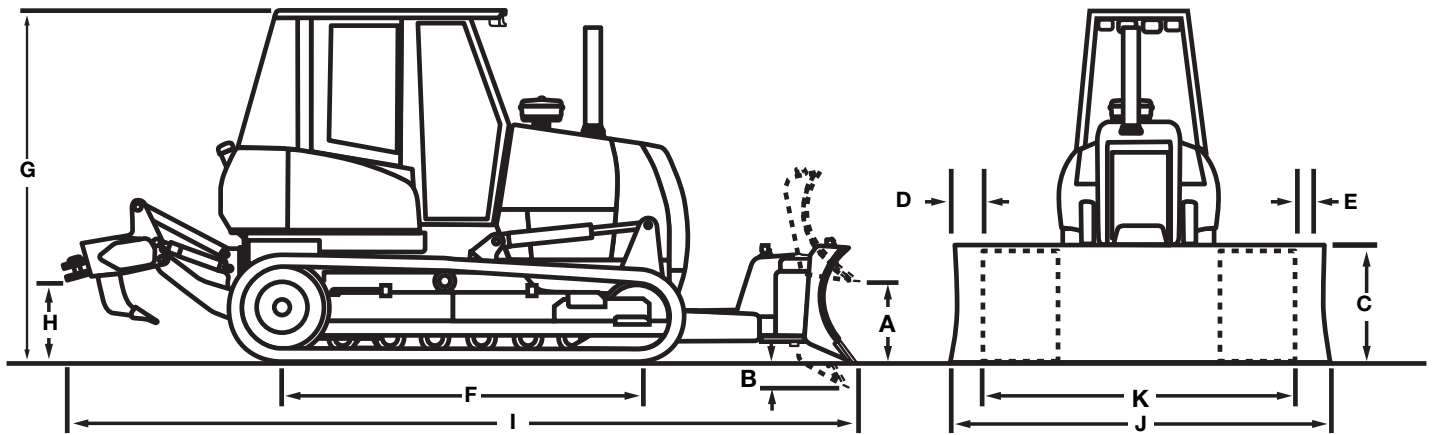

DIMENSIONS

	Long Track (XLT)	Wide Track (WT)	Low Ground Pressure (LGP)
BLADES			
Blade width	104 in (2642 mm)	110 in (2794 mm)	120 in (3048 mm)
SAE blade capacity	2.16 yd ³ (1.65 m ³)	2.32 yd ³ (1.77 m ³)	2.52 yd ³ (1.93 m ³)
A. Blade lift above ground	34.4 in (874 mm)	34.4 in (874 mm)	34.4 in (874 mm)
B. Blade depth below ground	19 in (483 mm)	19 in (483 mm)	19 in (483 mm)
Blade angle both directions	25°	25°	25°
Blade tilt, each end (up to 8.3°)	15 in (381 mm)	15.9 in (404 mm)	17.3 in (439 mm)
C. Blade height	36 in (914 mm)	36 in (914 mm)	36 in (914 mm)
D. Cast reach	13.7 in (348 mm)	16.4 in (417 mm)	13.9 in (353 mm)
E. Cut reach	0.7 in (18 mm)	3.5 in (86 mm)	-3.6 in (-91 mm)
TRACKS			
Track gauge	62 in (1.57 m)	62 in (1.57 m)	70 in (1.78 m)
Shoe width	20 in (508 mm)	20 in (508 mm)	24 in (610 mm)
F. Track on ground	93 in (2.35 m)	93 in (2.35 m)	93 in (2.35 m)
Area of track on ground	3704 in ² (2.38 m ²)	3704 in ² (2.38 m ²)	4449 in ² (2.87 m ²)
Ground pressure	5.3 psi (40.1 kPa)	5.3 psi (40.1 kPa)	4.5 psi (31.3 kPa)
DIMENSIONS			
G. Height to top of ROPS	109.2 in (2773 mm)	109.2 in (2773 mm)	109.2 in (2773 mm)
Height to top of cab	109.2 in (2773 mm)	109.2 in (2773 mm)	109.2 in (2773 mm)
with air conditioning	109.8 in (2788 mm)	109.8 in (2788 mm)	109.8 in (2788 mm)
H. Ground clearance w/drawbar	14.9 in (379 mm)	14.9 in (379 mm)	14.9 in (379 mm)
I. Length –			
Blade straight with drawbar	174 in (4408 mm)	174 in (4408 mm)	174 in (4408 mm)
Blade straight with ripper	206 in (5233 mm)	206 in (5233 mm)	206 in (5233 mm)
J. Width –			
Blade straight	104 in (2642 mm)	110 in (2794 mm)	120 in (3048 mm)
Blade angled	96 in (2446 mm)	102 in (2585 mm)	111 in (2815 mm)
K. Over track	80 in (2032 mm)	80 in (2032 mm)	94 in (2388 mm)

STANDARD EQUIPMENT

OPERATOR'S COMPARTMENT

Isolation mounted ROPS/FOPS canopy with headliner and floor mat
Vinyl suspension seat w/back adjustment & adjustable armrests
Retractable seat belt, 2 in (51 mm)
Foot rests

ENGINE

Case 668T/M2 diesel
Automatic fan belt tensioner
Integral engine oil cooling
Fuel filter
Dual element radial seal air cleaner
65 amp alternator
650 CCA 12-volt battery
Anti-sandblast radiator
Engine side panels
Anti-freeze to -34°F
Pusher fan

POWERTRAIN

Dual path infinitely variable, single-lever controlled hydrostatic drive with electronic straight tracking & counter-rotation, 4-position forward/reverse ratio control
Final drive – Triple reduction – helical gear/planetary. decelerator with hydrostatic drive retardation
Automatic spring applied parking brake

BLADE

52° - 60° variable pitch with integral adjustment tool
Single lever control for blade lift, angle and tilt

UNDERCARRIAGE

Easy clean track covers
Hydraulic track adjusters
Case Lubricated Track Chain
Permanently lubricated track and carrier rollers
Track adjuster guard
Track guides (front and rear)

OTHER

Backup alarm
Horn
Anti-vandalism package
Mirror
Pre-cleaner
Operator's manual enclosure
Master disconnect switch
Front pull hook
Hand throttle
Decelerator
Final drive seal guard
O-ring face seal hydraulic fittings
Vertical spin-on hydraulic & fuel filters

OPTIONAL EQUIPMENT

OPERATOR'S COMPARTMENT

Cab (w/heater, 25,598 BTU (7.5 kW)/hr air conditioner, defroster, front windshield washer and 2F-1R lights)
3 in (76 mm) seat belt
Deluxe air suspension seat

HYDRAULICS

4 spool hydraulic valve for field-installed ripper

REAR MOUNTED EQUIPMENT

Ripper, parallelogram 5 slot with 3 shanks

BLADES

104 in (2.6 m) or 110 in (2.8 m) XLT w/18 in (457 mm) shoes
110 in (2.6 m) or 120 in (3.0 m) WT w/24 in (610 mm) shoe
124 in (3.2 m) or 130 in (3.3 m) LGP w/28 in (711 mm) shoes

GUARDS

Sweeps
Center rockguard

SCREENS

Rear ROPS and cab
Side ROPS
Radiator brush

OTHER

Lights – halogen, 4 front, 2 rear for cab or ROPS
Counterweight, front
Retrieval hitch
Drawbar
Sprocket, relieved (XLT w/ CLT only)
Special paint
Dual 12V battery
Fan, reversible
Case Extended Life Track
Cold start aid
Turbo precleaner
Winch drive
Tool box for ROPS

NOTE: All specifications are stated in accordance with SAE Standards or Recommended Practices, where applicable.

NOTE: All engines meet current EPA emissions requirements.

IMPORTANT: CNH America LLC reserves the right to change these specifications without notice and without incurring any obligation relating to such change. CNH America LLC does not warrant the safety or reliability of attachments from other manufacturers.

Case is a registered trademark of CNH America LLC. Any trademarks referred to herein, in association with goods and/or services of companies other than CNH America LLC, are the property of those respective companies.



www.casece.com

 CASE IS A BRAND OF CNH,
A GLOBAL LEADER IN CONSTRUCTION EQUIPMENT, AGRICULTURAL EQUIPMENT AND FINANCIAL SERVICES.

Form No. CCE1190521
Same information as form no. CCE8060407

Printed in U.S.A.

© 2005 CNH America LLC
All Rights Reserved