

ENGINE

Model	Case Family IV, 445TA/E66, Tier III certified	
Cylinders	4	
Bore/Stroke	4.1 in x 5.2 in (104 x 132 mm)	
Displacement	274 in ³ (4.5 L)	
Fuel injection	Direct	
Fuel	#2 Diesel	
Fuel filter	Spin-on with in-line strainer	
Air intake	Cross-flow	
Cooling	Liquid	
Engine speeds (rpm)		
High idle - no load	2220±50	
Rated - full load	2000	
Low idle	800-1050	
Horsepower per SAE J1349		
Net	84 (62.6 kW) @ 2000 rpm	
Gross	90 (67.1 kW) @ 2000 rpm	
Peak torque @ 1400 rpm		
Net	288 lb-ft (391 N-m)	
Gross	295 lb-ft (400 N-m)	
Engine lubrication -		
Pump	Deep sump plate cooler with pressurized under-piston nozzles	
Pump operating angle ratings		
Side-to-side	45°	
Fore and aft	45°	
Oil filtration	Replaceable, spin-on full-flow cartridge	

ENGINE COOLING

Radiator -		
Core size area	583 in ² (0.38 m ²)	
Rows of tubes	4	
Fan -		
Diameter	21.6 in (550 mm)	
Ratio	0.875:1	

ELECTRICAL SYSTEM

Alternator	90 amp	
Battery	12-volt low-maintenance 700 cold-cranking amps @ 0° F (-18 C)	

POWERTRAIN

Dual path hydrostatic		
Pump - variable axial piston		
Motor - variable bent axis piston		
Maximum drawbar pull*	40,000 lb (178 kN)	
Transmission	Single lever control - electronic straight tracking	
Oil filter	4 micron, spin-on replaceable	
Travel speeds* -		
Forward	0-6 mph (0-9.7 km/h)	
Reverse	0-6 mph (0-9.7 km/h)	
*Measured using standard track chain. Increase travel speeds by 4% and reduce drawbar pull by 4% with the optional CELT track chain.		
Parking brakes	Heavy-duty, spring-applied, hydraulic pressure release	
Steering brakes	Hydrostatic	
Final drive	2 helical gear reduction to planetary output	
Ratio	62:1	

TRANSMISSION COOLING

Type	Oil to water	
Core size	431 in ² (.28 m ²)	

HYDRAULIC SYSTEM

Standard equipment pump		
Pump flow @ 2000 rpm		
@ 3000 psi (209 kPa)	20.3 gpm (76.8 L/min)	
Max. system pressure	3025±75 psi (20 855±515 kPa)	

CYLINDERS

Lift cylinder (2)		
Bore diameter	3.50 in (89 mm)	
Rod diameter	1.75 in (44.5 mm)	
Stroke	15.5 in (394 mm)	
Angle cylinder (2)		
Bore diameter	3.50 in (89 mm)	
Rod diameter	1.75 in (44.5 mm)	
Stroke	15.5 in (394 mm)	
Tilt cylinder (1)		
Bore diameter	3.50 in (89 mm)	
Rod diameter	1.75 in (44.5 mm)	
Stroke	5.80 in (144 mm)	

UNDERCARRIAGE

Track adjustment	Hydraulic	
Frame	Rigid suspension	
Length of track on ground	89 in (2266 mm)	
Track link pitch	6.73 in (171 mm)	
Track shoe height	2.06 in (52 mm)	
Pin diameter	1.32 in (33 mm)	
Bushing diameter -		
CLT track	2.24 in (57 mm)	
CELT track	3.0 in (76 mm)	
Bolt diameter	0.625 in (16 mm)	
Track shoes per side	39	
Track rollers per side	6	
Carrier rollers per side	1	
Track roller rail dia.	7.48 in (190 mm)	

TRACK ON GROUND

Shoe	Area - in ² (cm ²)	
18 in (457 mm)	3211 (20 716)	
20 in (508 mm)	3596 (22 032)	
24 in (610 mm)	4282 (27 626)	
28 in (711 mm)	4995 (32 226)	

TRACK

Long Track		
18 in (457 mm) closed grousers and CLT		
18 in (457 mm) open grousers and CELT		
20 in (508 mm) closed grousers and CLT		
20 in (508 mm) open grousers and CELT		
Wide Track		
18 in (457 mm) closed grousers and CLT		
18 in (457 mm) open grousers and CELT		
20 in (508 mm) closed grousers and CLT		
20 in (508 mm) open grousers and CELT		
24 in (610 mm) closed grousers and CLT		
24 in (610 mm) open grousers and CELT		
LGP		
28 in (711 mm) closed grousers and CLT		
28 in (711 mm) open grousers and CELT		

OPERATOR ENVIRONMENT

ROPS canopy
Single lever control for speed, steering and direction
Forward/reverse speed ratio selector
Adjustable armrests
Foot rests
Retractable seat belt, 2 in (51 mm)
Vinyl suspension seat w/back adjustment
Rear view mirror
Tool storage
Headliner
Floormat
Mirror

INSTRUMENTATION

Warning lights:

Air filter
Alternator
Diagnostic fault indicator
Engine coolant temperature
Engine oil pressure
Hydraulic filter
Low fuel level
Park brake engaged
Service soon indicator
Transmission filter
Transmission pressure
Transmission temperature

Gauges:

Battery voltage
Fuel level
Digital hourmeter/tachometer/diagnostic/service reminder
Transmission oil temperature
Transmission speed indicator
Water temperature

Audible warnings:

Engine coolant temperature
Engine oil pressure
Low fuel level
Transmission pressure
Temperature/hydraulic temperature

BLADE

Variable blade pitch	52° forward 60° rearward
Lift speed (per second)	18 in (457 mm)
Cutting edge	Reversible and replaceable
Width	8.0 in (203 mm)
Thickness	0.75 in (19 mm)

RIPPER

Max. penetration	14 in (356 mm)
Width	72.4 in (1839 mm)
Cut width	70.1 in (1780 mm)
Max. ground clearance	17.3 in (439 mm)
Points	Replaceable
Max. number of shanks	5
Tooth spacing –	
with 5 teeth	17.8 in (452 mm)
with 3 teeth	34 in (864 mm)
Hydraulic cylinder (double-acting)	
Diameter	3.25 in (82.6 mm)
Stroke	8.4 in (213 mm)
Rod	1.75 in (44.5 mm)

SERVICE CAPACITIES

Fuel tank	50 gal (189.3 L)
Engine oil w/filter	13 qt (12.3 L)
Engine oil w/o filter	12.2 qt (11.5 L)
Engine cooling system	24 qt (22.5 L)
Hydraulic reservoir	20 gal (75.7 L)
Final drive (per side)	15 qt (14.2 L)
Track rollers (ea.)	0.26 qt (0.25 L)
Front idlers (ea.)	0.52 qt (0.49 L)
Carrier rollers (ea.)	0.25 qt (0.24 L)

OPERATING WEIGHTS

Unit equipped with ROPS, full fuel tank, 170 lb (77 kg) operator, drawbar, side shield, track guides, backup alarm, horn and lights.

Long Track	18,900 lb (8569 kg)
Wide Track	19,700 lb (8955 kg)
LGP	20,200 lb (9157 kg)

Add-on weights –

Drawbar	85 lb (38 kg)
Ripper (3 shank)	1,400 lb (646 kg)
Winch	1,200 lb (545 kg)
Front counterweight	880 lb (399 kg)
Cab	930 lb (422 kg)
ROPS heater	71 lb (32 kg)
CELT chain	115 lb (52 kg)
Center rockguard	234 lb (106 kg)
Sweeps	104 lb (47 kg)
Dual batteries	64 lb (29 kg)

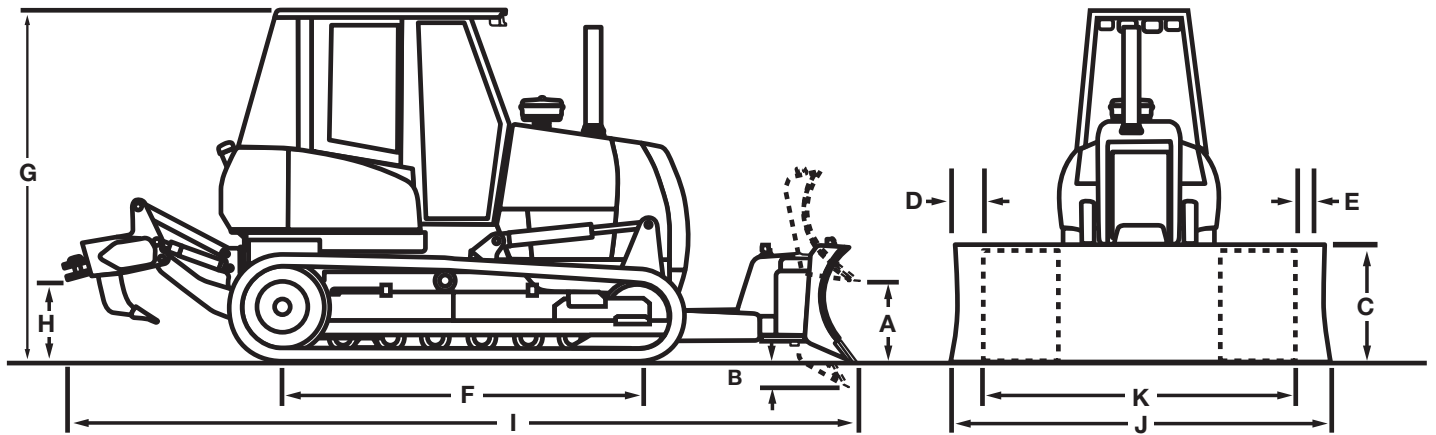

DIMENSIONS

	Long Track (LT)	Wide Track (WT)	Low Ground Pressure (LGP)
BLADES			
Blade width	104 in (2642 mm)	110 in (2794 mm)	110 in (2794 mm)
SAE blade capacity	2.16 yd ³ (1.65 m ³)	2.32 yd ³ (1.77 m ³)	2.32 yd ³ (1.77 m ³)
A. Blade lift above ground	34.4 in (874 mm)	34.4 in (874 mm)	34.4 in (874 mm)
B. Blade depth below ground	19 in (483 mm)	19 in (483 mm)	19 in (483 mm)
Blade angle both directions	25°	25°	25°
Blade tilt, each end (up to 8.3°)	15 in (381 mm)	15.9 in (404 mm)	15.9 in (404 mm)
C. Blade height	36 in (914 mm)	36 in (914 mm)	36 in (914 mm)
D. Cast reach	13.7 in (348 mm)	16.4 in (417 mm)	9.4 in (239 mm)
E. Cut reach	0.7 in (18 mm)	3.5 in (86 mm)	-3.6 in (-91 mm)
			0.9 in (23 mm)
			0.8 in (20 mm)
TRACKS			
Track gauge	62 in (1.57 m)	62 in (1.57 m)	70 in (1.78 m)
Shoe width	18 in (457 mm)	18 in (457 mm)	24 in (610 mm)
F. Track on ground	89 in (2.26 m)	89 in (2.26 m)	89 in (2.26 m)
Area of track on ground	3211 in ² (2.07 m ²)	3211 in ² (2.07 m ²)	4282 in ² (2.76 m ²)
Ground pressure	5.3 psi (40.1 kPa)	5.3 psi (40.1 kPa)	4.5 psi (31.3 kPa)
			4.5 psi (31.3 kPa)
			4.0 psi (27.6 kPa)
DIMENSIONS			
G. Height to top of ROPS	109.2 in (2773 mm)	109.2 in (2773 mm)	109.2 in (2773 mm)
Height to top of cab	109.2 in (2773 mm)	109.2 in (2773 mm)	109.2 in (2773 mm)
with air conditioning	109.8 in (2788 mm)	109.8 in (2788 mm)	109.8 in (2788 mm)
H. Ground clearance w/drawbar	14.9 in (379 mm)	14.9 in (379 mm)	14.9 in (379 mm)
I. Length -			
Blade straight with drawbar	170 in (4322 mm)	170 in (4322 mm)	170 in (4322 mm)
Blade straight with ripper	203 in (5147 mm)	203 in (5147 mm)	203 in (5147 mm)
J. Width -			
Blade straight	104 in (2642 mm)	110 in (2794 mm)	110 in (2794 mm)
Blade angled	96 in (2446 mm)	102 in (2585 mm)	102 in (2585 mm)
K. Over track	80 in (2032 mm)	80 in (2032 mm)	94 in (2388 mm)
			94 in (2388 mm)
			98 in (2489 mm)

STANDARD EQUIPMENT

OPERATOR'S COMPARTMENT

Isolation mounted ROPS/FOPS canopy with headliner and floor mat
Vinyl suspension seat w/back adjustment & adjustable armrests
Retractable seat belt, 2 in (51 mm)
Foot rests

ENGINE

Case 445TA/E66
Automatic fan belt tensioner
Integral engine oil cooling
Fuel filter
Dual element air cleaner
90 amp alternator
700 CCA 12-volt battery
Anti-sandblast radiator
Engine side panels
Anti-freeze to -34°F
Pusher fan

POWERTRAIN

Dual path infinitely variable, single-lever controlled hydrostatic drive with electronic straight tracking, power turns & counter-rotation, 4-position forward/reverse ratio control
Final drive – Triple reduction – helical gear/planetary. decelerator with hydrostatic drive retardation
Automatic spring applied hydraulic release parking brake

BLADE

52° - 60° variable pitch with integral adjustment tool
Single lever control for blade lift, angle and tilt

UNDERCARRIAGE

Easy clean track covers
Hydraulic track adjusters
Case Lubricated Track Chain
Permanently lubricated track and carrier rollers
Track adjuster guard
Track guides (front and rear)
Shock resistance idler mounting

OTHER

Backup alarm
Horn
Anti-vandalism package
Mirror
Pre-cleaner
Operator's manual enclosure
Master disconnect switch
Front pull hook
Hand throttle
Decelerator
Final drive seal guard
O-ring face seal hydraulic fittings
Vertical spin-on hydraulic & fuel filters
Hinged grill with tether
Tool storage area

OPTIONAL EQUIPMENT

OPERATOR'S COMPARTMENT

Cab (w/heater, 25,598 BTU (7.5 kW)/hr air conditioner, defroster, front windshield washer and 2F-1R lights)
3 in (76 mm) seat belt
Deluxe air suspension seat

HYDRAULICS

4 spool hydraulic valve for field-installed ripper

REAR MOUNTED EQUIPMENT

Ripper, parallelogram 5 slot with 3 shanks

BLADES

104 in (2.6 m) or 110 in (2.6 m) LT w/18 in (457 mm) shoes
110 in (2.6 m) or 120 in (3.0 m) WT w/20 in (508 mm) shoes
120 in (3.0 m) WT w/24 in (610 mm) shoes
124 in (3.15 m) LGP w/28 in (711 mm) shoes
130 in (3.3 m) LGP w/28 in (711 mm) shoes

GUARDS

Sweeps
Center rockguard

SCREENS

Rear ROPS and cab
Side ROPS
Radiator brush

OTHER

Lights – halogen, 4 front, 2 rear for cab or ROPS
Counterweight, front
Retrieval hitch
Drawbar
Special paint
Case Extended Life Track
Cold start aid with dual batteries
Turbo precleaner
Winch drive

NOTE: All specifications are stated in accordance with SAE Standards or Recommended Practices, where applicable.

NOTE: All engines meet current EPA emissions requirements.

IMPORTANT: Case Construction Inc. reserves the right to change these specifications without notice and without incurring any obligation relating to such change. Case Construction Inc. does not warrant the safety or reliability of attachments from other manufacturers.

Case is a registered trademark of CNH America LLC. Any trademarks referred to herein, in association with goods and/or services of companies other than CNH America LLC, are the property of those respective companies.



www.casece.com