

ENGINE

570M XT

Model	Case Family III 445T/M3 diesel, Tier III Certified
Type	4-stroke, turbocharged
Cylinders	4
Bore/Stroke	4.09 in x 5.19 in (104 mm X 132 mm)
Displacement	274 in ³ (4.5 L)
Fuel injection	Direct
Fuel	#2 Diesel
Fuel filter	w/water trap
Air intake	Cross-flow
Cooling	Liquid
Engine speeds (rpm)	
Rated speed, full load	2200
Low idle	850 - 1000
High idle, no load	2300 - 2450
Horsepower	
Gross	85 (63 kW) @ 2200 rpm
Net	79 (59 kW) @ 2200 rpm
Maximum torque @ 1400 rpm	
Gross	276 lb-ft (374 N·m)
Net	270 lb-ft (366 N·m)
Torque rise at rated speed	33%

ENGINE COOLING

Radiator	
Core type	Square wave
Core size area	486 in ² (.31 m ²)
Rows of tubes	3
Fan	
Style	7 blade suction
Diameter	19.7 in (500 mm)
Ratio	1.1:1
Water pump	
Style	Integral
Engine oil	
Pump	Deep sump plate cooler with pressurized under-piston nozzles
Pump operating angle ratings	
Side-to-side	Rated 35°
Fore and aft	Rated 35°
Oil filtration	Replaceable, full-flow cartridge

POWERTRAIN

Transmission	4-speed synchromesh with hydraulically actuated clutches and electric F/R shuttle control, clutch disconnect buttons on the transmission shifter and loader control lever		
Gear ratios	Forward	Reverse	
1st	5.491	5.491	
2nd	3.043	3.043	
3rd	1.584	1.584	
4th	0.793	0.793	
Torque converter			
Ratio	3.2		
Differential-lock	On-the-go push-button activation		
Front axle			
Differential ratio	2.0		
Planetary hub ratio	6.0		
Total reduction ratio	12.0		
Rear axle			
Differential ratio	2.333		
Planetary hub ratio	6.923		
Total reduction ratio	16.153		
Service brakes	Individually applied hydraulically actuated maintenance-free self-adjusting inboard mounted wet disc		
Disc area	53 in ² (.03 m ²)		

Parking brakes	Mechanically applied with electric activation sensors at each brake			
Travel speeds – mph (km/h)				
	1st	2nd	3rd	4th
Forward	3.8 (6.1)	6.9 (11.1)	13.0 (21.0)	25.2 (40.5)
Reverse	3.8 (6.1)	6.7 (11.1)	13.0 (21.0)	25.2 (40.5)

NOTE: Travel speeds at 2334 engine rpm with 19.5L x 24 rear tires. Speeds decrease with 17.5L x 24 rear tires.

ELECTRICAL

Voltage	12 Volts, negative ground
Alternator	90 amp (2.5 kW)
Battery	685 cold-cranking amps
Optional batteries	(2) 525 cold-cranking amps

HYDRAULICS

Pump	Gear-type, transmission mounted	
Loader flow @ rated engine rpm	28.5 gpm @ 3000 psi (108 L/min @ 207 bar)	
Loader control valve	Sectional 2 or 3-spool with single lever control for lift, tilt and auxiliary hydraulics, positive hold float and return-to-dig	
3-pt. hitch flow @ rated engine rpm	0 to 8 gpm @ 2000 psi (0 to 30 L/min @ 137 bar)	
3-pt. hitch control valve	Sectional 4-spool, open-center parallel circuits with variable control for lift, pitch, tilt and 1 auxiliary	
Loader auxiliary hydraulics	12 to 28.5 gpm (45.4 to 108 L/min)	
Main relief pressure	3050 + 50 - 50 psi @ 28.5 gpm (210 + 3 - 3 bar @ 108 L/min)	
Filtration	7-micron, full flow replaceable cartridge on return line, condition indicator light for filter	
Oil cooler	Heavy-duty	

OPERATOR ENVIRONMENT

ROPS/FOPS canopy
Key start
Hydrostatic steering
Standard seat w/15° and 30° swivel to the right
Hand and foot throttles
Loader control lever w/push-button activation of differential lock and transmission de-clutch
(2) Accessory power plugs (30 amp)
Anti-vandalism covers (canopy only)
Beverage holder
Coat hook w/tether strap
Interior rear-view mirror
2 in (51 mm) retractable seat belt
Storage box

INSTRUMENTATION

Gauges - back lit
Engine water temperature
Converter oil temperature
Fuel
Tachometer/hourmeter
Voltmeter
Warning lights
Air cleaner restriction
Alternator
Engine oil pressure
Hydraulic oil filter bypass
Parking brake engagement
Rear axle fluid temperature sensing system
Low fuel
Audible alarms
Coolant temperature
Engine oil pressure
Parking brake engagement
Shuttle engagement
Backup alarm
Turn signal indicators
Horn - dual switched front & rear

TURNING DIAMETER

2WD	
Brakes on	24 ft 3 in (7.39 m)
Brakes off	25 ft 8 in (7.82 m)
4WD – engaged	
Brakes on	23 ft 1 in (7.04 m)
Brakes off	27 ft 5 in (8.36 m)
4WD – disengaged	
Brakes on	24 ft 5 in (7.44 m)
Brakes off	25 ft 9 in (7.85 m)

NOTE: Turning diameter dimensions curb to curb w/82 in (2.08 m) general purpose bucket.

OPERATING WEIGHTS

Lightest Configuration
Unit equipped with 2WD, ROPS/FOPS canopy, non-suspension seat, 82 in (2.08 m) general purpose loader bucket, 3-point hitch, 527 lb (239 kg) counterweight, 17.5L x 24 rear tires, 11L x 16.1 front tires, single battery, no operator.

570M XT	10,537* lb (4779 kg)
---------	----------------------

*Less 20 lb (8.7 kg) valve

Heaviest Configuration

Unit equipped with 4WD, cab, suspension seat, 82 in (2.08 m) 4 IN 1® loader bucket, 3-point hitch, 527 lb (239 kg) counterweight, box scraper, 19.5L x 24 rear tires, 12L x 16.5 front tires, dual batteries, 440 lb (200 kg) front counterweight, 485 lb (220 kg) plug in weight, no operator.

570M XT	14,601* lb (6623 kg)
---------	----------------------

*Less 20 lb (8.7 kg) valve

Add-on weights

Cab (over canopy)	+454 lb (206 kg)
Loader only version 3,000 lb (1361 kg) counterweight ILO 600 lb (272 kg) counterweight	+2,400 lb (1089 kg)
Box Scraper	+1,422 lb (645 kg)
4WD w/driveshaft guard	+ 283 lb (128 kg)
Front counterweight	+440 lb (200 kg)
Wheel weight	+564 lb (256 kg)

SERVICE CAPACITIES

Fuel tank	31.4 gal (119 L)
Optional tank	40.0 gal (151 L)
Hydraulic system	
Total	20.25 gal (77 L)
Reservoir w/filter	14.5 gal (54.9 L)
Reservoir w/o filter	14.0 gal (53 L)
Transmission	
2WD Total system	19.0 qt (18 L)
4WD Total system	22.0 qt (20.8 L)
4WD Front axle	
Differential	5.8 qt (5.5 L)
Planetaries (each)	0.7 qt (0.66 L)
Rear axle	
Differential	15.0 qt (14.2 L)
Planetaries (each)	1.6 qt (1.5 L)
Engine oil w/filter	14.4 qt (13.6 L)
Cooling system	
w/heater	17.8 qt (16.8 L)
w/o heater	17 qt (16.1 L)
Window washer reservoir	2.5 qt (2.36 L)

LOADER

Single-lever control for lift and tilt
Positive hold float
Return-to-dig
Automatic self-leveling
In-line, reverse linkage
Dual parallel dump cylinders
Clutch disconnect button on loader control and shift levers
Bucket position indicator

Loader Bucket Sizes

Width	Weight	Struck	Heaped
General Purpose Bucket			
82 in (2.08 m)	686 lb* (311 kg)	0.87 yd³ (0.67 m³)	1.03 yd³ (0.79 m³)
4 IN 1® Bucket			
82 in (2.08 m)	1462 lb (663 kg)	0.85 yd³ (0.65 m³)	1.04 yd³ (0.80 m³)

NOTE: *Add 103 lb (47 kg) to 82 in (2.08 m) general purpose bucket for bolt-on cutting edge.

LOADER CYCLE TIME

Raise to full height	5.3 sec
Bucket dump	1.1 sec
Power down	2.4 sec
Return-to-dig	3.2 sec
4 IN 1® clam open	2.28 sec
4 IN 1® clam close	3.13 sec

3 PT. HITCH

Category I & II 3-point hitch
Hydraulic lift, pitch, tilt and (2) auxiliary remotes
Variable flow from 0 to 8 gpm (0 to 30 L/min)
527 lb (239 kg) counterweight included w/hitch

3-point Hitch Lift Capacity

Hitch Position*	
Lowest Point	11,121 N
1/5	14,444 N
2/5	15,125 N
3/5	15,125 N
4/5	14,666 N
Highest Point	13,274 N

NOTE: *Hitch position is vertical distance of lowest hitch point above ground.

TIRES

Front	
2WD – 11L x 16.1, 10-ply rating	
4WD – 12 x 16.5, 8-ply rating	
Rear	
2/4WD – 17.5L x 24, 10-ply rating	
2/4WD – 19.5L x 24, 10-ply rating	

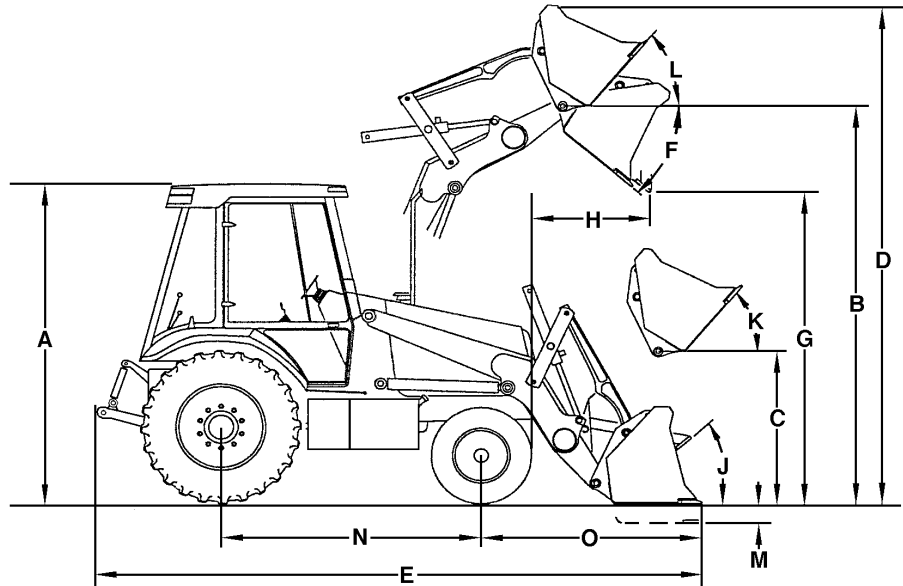

LOADER DIMENSIONS

	General Purpose Bucket	4 IN 1@ Bucket
Height to –		
A. Top of canopy		8 ft 11 in (2.72 m)
A. Top of cab		9 ft 0 in (2.74 m)
B. Bucket hinge pin fully raised	11 ft 2 in (3.4 m)	11 ft 2 in (3.4 m)
C. Bucket hinge pin @ SAE carry	12.8 in (325 mm)	14.6 in (372 mm)
D. Overall operating height – fully raised	13 ft 8 in (4.17 m)	14 ft 3 in (4.35 m)
E. Overall length	16 ft 11 in (5.15 m)	16 ft 8 in (5.09m)
Width over tires –		
11L x 16		79.3 in (2.02 m)
12 x 16.5		81.1 in (2.06 m)
19.5L x 24		81.4 in (2.07 m)
17.5L x 24		81.7 in (2.08 m)
F. Dump angle @ full height	46°	45°
G. Dump clearance @ full height, 45° dump –		
Bucket	8 ft 8 in (2.64 m)	8 ft 11 in (2.72 m)
Clam open	NA	9 ft 8 in (2.95 m)
H. Dump reach @ full height, 45° dump –		
Bucket	25.9 in (657 mm)	25.4 in (644 mm)
Clam open	NA	11.8 in (300 mm)
Bucket rollback –		
J. @ groundline	40°	40°
K. @ SAE carry	45°	45°
L. @ full height	Adjustable	Adjustable
M. Digging depth below grade –		
Bucket flat	7.8 in (199 mm)	7.1 in (180 mm)
Clam open (dozing)	NA	4.4 in (111 mm)
Ground clearance at front axle	10.9 in (276 mm)	
N. Wheelbase –		
2WD		84 in (2.13 m)
4WD		84.5 in (2.15 m)
O. Reach from front axle centerline – bucket on ground	75.2 in (1.91 m)	72.7 in (1.85 m)
Maximum clam opening	NA	38.3 in (972 mm)
Moldboard height	NA	36.8 in (934 mm)
Lift capacity to full height	6,503 lb (2956 kg)	6,537 lb (2971 kg)
Breakout force –		
Lift cylinders	9,271 lbf (41 239 N)	8,766 lbf (38 993 N)
Dump cylinders	9,607 lbf (42 734 N)	10,325 lbf (45 928 N)

NOTE: Loader dimensions taken with 4WD, 19.5L x 24 rear tires and 82 in (2.08 m) general purpose bucket except as noted.

STANDARD EQUIPMENT

OPERATOR'S COMPARTMENT

See page 2

ENGINE

Case Family III 445T/M3 turbocharged
Automatic fan belt tensioner
Integral engine oil cooling
Fuel filter w/water trap
Air intake pre-cleaner
Dual element air cleaner
90 amp alternator
685 CCA 12-volt battery
Heavy-duty radiator

LOADER

See page 2

POWERTRAIN

2WD
4F/4R Power shuttle synchromesh transmission
Torque converter
Transmission de-clutch
Electro-hydraulic differential lock
Hydrostatic steering
Disc brakes

HYDRAULICS

2-spool loader control valve
4-spool 3-point hitch control valve
Heavy-duty oil cooler

OTHER

Forward tilt engine hood
Replaceable, molded front bumpers
Lights
(2) Halogen headlights
(2) Rear flood
(2) Rear tail and stop
(2) Front flashers/turn
(2) Rear flashers/turn

OPTIONAL EQUIPMENT

OPERATOR'S COMPARTMENT

Low profile ROPS/canopy
Ride Control
Cab with –
Defroster
Dome light
Wipers, front and rear
Tinted glass
Floor mat
Cab Convenience Package with –
Vinyl-covered cloth interior
Radio-ready kit w/antenna and speakers
Reduced sound level to 75 dB(A)
Window washers w/adjustable spray nozzles front and rear
Sunvisor
Sunvisor for canopy models
Vinyl or cloth covered mechanical suspension seat w/armrests
3 in (75 mm) retractable seat belt
Cab heater
Cab air-conditioning w/heater
Hand throttle

ENGINE

Cold weather grid heater/dual battery
Dual, 12-volt, 525 CCA batteries
Fuel tank, 40 gal (151 L)

POWERTRAIN

4WD w/outboard planetary drive, on-the-go push-button activation and 12 x 16.5 front tires

HYDRAULICS

Auxiliary hydraulics for hand-held equipment
Anti drift and inreturn-to-position in valve

LOADER

Loader only version (without 3-point hitch)
Hydraulic attachment coupler
Attachment auxiliary hydraulics
Buckets (see page 2)

OTHER

17.5L x 24 rear tires
19.5L x 24 rear tires
Tool box
Drawbar
Special paint
Lights
(2) Front flood
(2) Rear flood
440 lb (200 kg) Front counterweight
Galaxy tires - Front
4WD 12L x 16.5 Soft Flex-Poly Fill
Galaxy tires - Rear
2/4WD 19.5L x 24 w/Tyrllyner™

NOTE: All specifications are stated in accordance with SAE Standards or Recommended Practices, where applicable.

NOTE: All engines meet current EPA emissions requirements.

IMPORTANT: Case Construction Equipment Inc. reserves the right to change these specifications without notice and without incurring any obligation relating to such change. Case Construction Equipment Inc. does not warrant the safety or reliability of attachments from other manufacturers.

Case is a registered trademark of CNH America LLC. Any trademarks referred to herein, in association with goods and/or services of companies other than CNH America LLC, are the property of those respective companies.



www.casece.com