

ENGINE

Model	ISM 422T/M3 diesel, Tier III certified	
Type	4-stroke, turbocharged	
Cylinders	4	
Bore/Stroke	3.3 in x 3.93 in (84 mm x 100 mm)	
Displacement	135 in ³ (2.2 L)	
Fuel injection	Indirect	
Fuel	#2 Diesel	
Fuel filter	In-line strainer	
Air intake	Cross-flow	
Cooling	Liquid	
Engine speeds (rpm)		
High idle – no load	3080±50	
Rated – full load	2900	
Low idle	1200±50	
Horsepower per SAE J1349		
Gross	60 (45 kW) @ 2900 rpm	
Net	57 (42 kW) @ 2900 rpm	
Peak torque		
@ 1700 rpm	126 lb-ft (170 N·m)	

ENGINE COOLING

Radiator		
Core type	Square wave serpentine	
Core size area	377 in ² (.243 m ²)	
Rows of tubes	4	
Cap pressure	14 psi (96.5 kPa)	
Fan		
Diameter	16.9 in (430 mm)	
Ratio	1.15:1	
Water pump		
Style	Centrifugal	
Flow	17.2 gpm (65 L/min)	
Engine lubrication		
Pump operating angle ratings		
Side-to-side	Rated 30°	
Fore and aft	Rated 30°	
Oil filtration	Replaceable, full-flow cartridge	

POWERTRAIN

Drive pump	Tandem, axial piston hydrostatic transmission with integral charge pump driven directly off engine flywheel	
Pump to engine ratio	1:1	
Displacement	0 to 2.3 in ³ (37.69 cc)	
Pump flow @ high idle engine rpm	30.6 gpm (116 L/min)	
Flow	Bi-directional	
Charge pressure	360 psi (24.8 bar)	
System relief	4350 psi (300 bar)	
Controls	Servo	
Drive motors	Fixed displacement radial piston	
Maximum displacement	24.4 in ³ (400 cc)	
Speed @ rated engine rpm @ max displacement	290 rpm	
Torque @ max displacement and relief pressure	1,408 lb-ft (1909 N·m)	
Travel speed	6.5 mph (10.5 km/h)	
Final drive	Single-reduction chain drive	

Drive chain		
Size	ASA #80HS	
Tensile strength	21,000 lb (93 413 N)	
Axles	One-piece, forged induction-hardened high carbon steel	
Torque @ max displacement and relief pressure	4,436 lb-ft (6014 N·m)	
Diameter	2.0 in (51 mm)	
Length	14.6 in (371 mm)	

Parking brakes	Spring applied, hydraulic release disc	
Engagement	Depress on/off brake button on handle or instrument panel, raise seat bar, get off seat, or stop engine	

HYDRAULIC SYSTEM

Standard equipment pump	Gear pump	
Type	Gear pump	
Displacement	1.55 in ³ /rev (25.4 cc)	
Pump flow @ rated engine rpm		
Total	19.5 gpm (73.8 L/min)	
Optional high flow	26.7 gpm (101 L/min)	
Loader control valve	3-spool open-center series with power beyond port	
Relief pressure	3050 psi (210 bar)	
Port relief pressures		
Loader Raise	3120 psi (215 bar)	
Bucket Dump	3800 psi (260 bar)	
Bucket Curl	3350 psi (230 bar)	
Hydraulic lines		
Tubing	37° JIC Flare	
Loop hoses	SAE 100 R12	
Hydraulic oil cooler	Four row in-line	
Core type	Four row in-line	
Hydraulic filter	6 micron spin-on replaceable element on the return line with warning indicator	

INSTRUMENTATION

Indicators	
Digital Hourmeter	
Fuel level LCD bar graph with alarm	
Warning lights with alarms	
Engine coolant temperature	
Engine oil pressure	
Engine Malfunction	
Hydraulic charge pressure	
Hydraulic filter restriction	
Hydraulic oil temperature	
Warning alarms	
Battery voltage (plus display)	
Indicator light	
Engine preheat	
Parking brake	
Seat bar reminder	

ELECTRICAL SYSTEM

Alternator	55 amp
Starter	2.0 kW
Battery	
12-volt low-maintenance 1125 cold-cranking amps @ 0° F (-18° C)	

OPERATOR ENVIRONMENT

ROPS/FOPS level 1 canopy w/side screens
Control lockout system
Tilt ROPS/FOPS
Rear window w/ emergency escape
Instrument panels
Suspension vinyl seat
2 in (51 mm) retractable seat belt
Hand throttle
Foot throttle
Alarm package
Headliner
Top window
Cup holder
Power plug socket
Foot rest
Storage tray
Low effort ergonomic hand controls
Padded seat bar w/integral armrests
Loader control lockout system
Electric parking brake control
Floor cleanout panel

CYLINDERS

Lift cylinder	
Bore diameter	2.25 in (57.2 mm)
Rod diameter	1.5 in (38.1 mm)
Stroke	35.2 in (893 mm)
Closed length	46.2 in (1173 mm)
Bucket cylinder	
Bore diameter	2.5 in (63.5 mm)
Rod diameter	1.37 in (34.8 mm)
Stroke	14.5 in (368 mm)
Closed length	26.9 in (683 mm)

OPERATING WEIGHTS

Unit equipped with 10.00 x 16.5 Galaxy Beefy Baby II tires, 60 in (1.5 m) foundry/excavating bucket, mechanical attachment coupler, full fuel tank and 165 lb (75 kg) operator	
	5,430 lb (2463 kg)
Shipping weight	4,880 lb (2213 kg)
Add-on weights	
Side cab glass	+70 lb (32 kg)
Lexan® door	+50 lb (22.6 kg)
Glass door w/wiper	+77 lb (35 kg)
Suspension seat	+10 lb (4.5 kg)

SERVICE CAPACITIES

Fuel tank	22.0 gal (83.3 L)
Engine oil w/filter	11 qt (10.5 L)
Engine cooling system	12 qt (11.5 L)
Hydraulic system	
Reservoir	7.1 gal (26.8 L)
Total	13.2 gal (50 L)
Chain tanks (per side)	8 qt (7.6 L)

TIRE SELECTION

	Size	Ply Rating	Tread Depth	Tire Width	Width Over Tires	Tire Weight*
Galaxy XD2002	10.00 x 16.5	8	0.59 in (15 mm)	10.7 in (284 mm)	59 in (1.50 m)	52 lb (23.6 kg)
Galaxy Beefy Baby II	10.00 x 16.5	8	0.75 in (19 mm)	10.2 in (259 mm)	59 in (1.50 m)	61 lb (27.6 kg)
Galaxy Hulk	10.00 x 16.5	10	1.37 in (35 mm)	10.2 in (259 mm)	59 in (1.50 m)	79 lb (35.8 kg)
Galaxy Hippo	31.5 x 16.5	8	.75 in (19 mm)	12.8 in (325 mm)	64 in (1.63 m)	70 lb (31.7 kg)
Galaxy Solid Flex	10 x 16.5	n/a	.7 in (18 mm)	9.6 in (244 mm)	61 in (1.50 m)	230 lb (104 kg)
Galaxy Solid Flex (offset wheel)	10 x 16.5	n/a	.7 in (18 mm)	9.6 in (244 mm)	67 in (1.70 m)	230 lb (104 kg)

*Tire weight does not include the wheel weight.

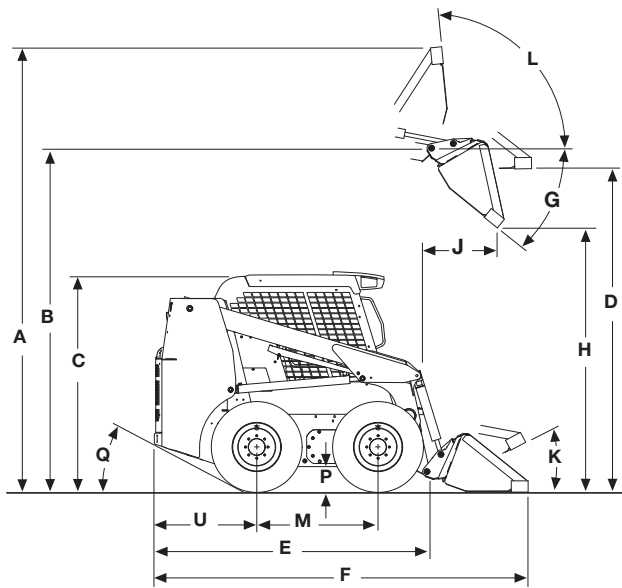

DIMENSIONS*

A.	Overall operating height	
	w/foundry/excavating bucket – short lip	145.7 in (3.70 m)
	w/low profile bucket – standard lip	151.3 in (3.84 m)
	w/low profile extended bucket – long lip	156.3 in (3.97 m)
	Height to	
B.	Bucket hinge pin	114.9 in (2.92 m)
C.	Top of rollover protective structure	78.9 in (2.00 m)
D.	Bottom of level bucket, loader arm fully raised	107.8 in (2.74 m)
	Overall length	
E.	w/o attachment w/coupler	97.9 in (2.49 m)
F.	w/foundry/excavating bucket on ground	123.3 in (3.13 m)
F.	w/low profile bucket on ground	129.1 in (3.28 m)
F.	w/low profile extended bucket on ground	134 in (3.40 m)
G.	Dump angle at maximum height	40°
H.	Dump height – loader arm fully raised	
	w/foundry/excavating bucket	90 in (2.29 m)
	w/low profile bucket	85.9 in (2.18 m)
	w/low profile extended bucket	82.7 in (2.10 m)
J.	Dump reach – loader arm fully raised	
	w/foundry/excavating bucket	23.8 in (0.60 m)
	w/low profile bucket	28.1 in (0.71 m)
	w/low profile extended bucket	31.9 in (0.81 m)
	Maximum attachment rollback	
K.	Bucket on ground	28°
L.	Bucket at full height	94°
M.	Wheelbase	41.2 in (1.05 m)
	Ground clearance	
P.	Bottom of belly pan	8.4 in (212 mm)
Q.	Angle of departure	27°
	Clearance circle front	
R.	Less bucket	54 in (1.37 m)
S.	w/60 in (1.52 m) foundry/excavating bucket on ground	73.4 in (1.86 m)
S.	w/60 in (1.52 m) low profile bucket on ground	78.6 in (1.99 m)
S.	w/60 in (1.52 m) low profile extended bucket on ground	83.3 in (2.11 m)
T.	Clearance circle rear	57.6 in (1.46 m)
U.	Rear axle to bumper	35.8 in (0.90 m)
V.	Tread width, centerline to centerline	48.4 in (1.23 m)

NOTE: *Equipped with 10.00 x 16.5 Galaxy Beefy Baby II tires.

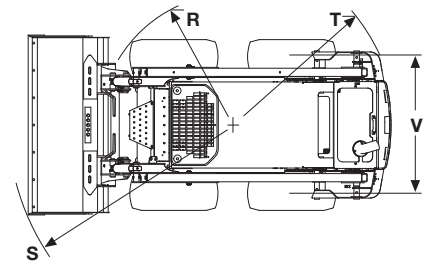

PERFORMANCE SPECS

Operating load	1,500 lb (681 kg)
Tipping load	3,000 lb (1361 kg)
Breakout force	
Lift cylinder	3,751 lbf (16 685 N)
Bucket cylinder	4,654 lbf (20 702 N)
Dig depth	
w/bucket flat	0.2 in (6 mm)
Cycle time	
Raise	3.6 seconds
Lower	2.1 seconds
Dump	1.3 seconds
Rollback	1.5 seconds

NOTE: SAE rated lift capacities. Breakout force and cycle time measured with rated load in F/E bucket.

OPTIONAL BUCKETS

Type	Width inch (m)	Weight lb (kg)	Heaped Capacity ft ³ (m ³)
Foundry/ Excavating	60 (1.5)	270 (122)	11.5 (0.33)
	66 (1.6)	370 (168)	15.2 (0.43)
	72 (1.8)	390 (177)	16.7 (0.47)
	60 (1.5)	330 (150)	11.5 (0.33)
Low Profile	66 (1.6)	400 (181)	13.2 (0.37)
	72 (1.8)	425 (193)	14.5 (0.41)
	60 (1.5)	360 (163)	14.3 (0.40)
Low Profile Extended	66 (1.6)	434 (197)	15.5 (0.44)
	60 (1.5)	350 (159)	19.7 (0.56)
Utility/Light Material	72 (1.8)	434 (197)	23.7 (0.67)
	84 (2.1)	497 (225)	27.9 (0.79)

STANDARD EQUIPMENT

OPERATOR'S COMPARTMENT

ROPS/FOPS level 1 canopy w/side screens
Control lockout system
Tilt ROPS/FOPS
Rear window w/emergency escape
Instrument panels
Suspension vinyl seat
2 in (51 mm) retractable seat belt
Hand throttle
Foot throttle
Alarm package
Headliner
Top window
Cup holder
Power plug socket
Foot rest
Storage tray
Low effort ergonomic hand controls
Padded seat bar w/integral armrests
Loader control lockout system
Electric parking brake control
Floor cleanout panel

OPTIONAL EQUIPMENT

OPERATOR'S COMPARTMENT

Deluxe cloth suspension seat w/heater and lumbar support
3 in (76 mm) retractable seat belt
Interior mirror
Radio
Heat and A/C
Demo door
Auxiliary front electric controls
Glass front door w/wiper & washer
Sliding side windows

LOADER

Radial loader arm design
Mechanical attachment coupler
Loader lift arm support strut

ENGINE

Case/ISM 422T/M3 diesel
Integral engine oil cooling
Fuel filter w/water trap
Dual element air cleaner
55 amp alternator
1125 CCA 12-volt battery
Glow plug
Side-by-side radiator and oil cooler
Spark arresting muffler

POWERTRAIN

Hydrostatic four wheel drive
Servo controls
ASA #80HS drive chain
SAHR disc parking brakes

HYDRAULICS

Auxiliary hydraulics 3050 psi (210 bar) – 19.5 gpm (73.8 L/min)
Hydraulic circuit pedal lock
Loader arm-mounted ISO flat face connectors
Auxiliary function lockout override
Loader function lockout system
Loader lift lockout override
3-spool loader control valve
Heavy-duty oil cooler
Loader arm float position

OTHER

Integral bumper counterweight
Lockable service access hood
Single-point daily servicing
Halogen lights, 2-front, 2 side, 1-rear flood (halogen)
Rear tail lights
Options harness
Remote oil drain

LOADER

Auxiliary front electric control
Ride control
Hydraulic attachment coupler
Hydraulic one-way self-leveling
Pilot controls
High flow hydraulics
Attachment case drain plumbing

ENGINE

Coolant block heater

OTHER

2 speed
Deluxe instrument panel
Road lights
Rotating beacon
Lift hooks
Special paint
Language decals
Factory-installed tires – see page 2
Buckets – see page 3
Bolt-on bucket cutting edges
42 in (1.07 m) and 48 in (1.22 m) pallet forks
Battery disconnect switch / jump start terminals
Steel tracks

NOTE: All specifications are stated in accordance with SAE Standards or Recommended Practices, where applicable.

NOTE: All engines meet current EPA emissions requirements.

IMPORTANT: Case Construction Equipment Inc. reserves the right to change these specifications without notice and without incurring any obligation relating to such change. Case Construction Equipment Inc. does not warrant the safety or reliability of attachments from other manufacturers.

Case is a registered trademark of CNH America LLC. Any trademarks referred to herein, in association with goods and/or services of companies other than CNH America LLC, are the property of those respective companies.



www.casece.com