

ENGINE

Model	Case 432T/M3
Type	4-stroke
Cylinders	4
Bore/Stroke	3.89 in x 4.09 in (99 X 104 mm)
Displacement	195 in ³ (3.2 L)
Fuel injection	Direct
Fuel	#2 Diesel
Fuel filter	Replaceable, full flow spin-on cartridge
Air filter	Dry type element w/warning restriction indicator
Radiator	
Core type	Staggered
Fan	
Style	Direct drive
Lubrication/cooling oil pump	
Style	Integral
Engine oil	
Pump	Deep sump plate cooler with pressurized under-piston nozzles
Pump operating angle ratings	
Side-to-side	Rated 35°
Fore and aft	Rated 35°
Oil filtration	Replaceable, full flow spin-on cartridge
Engine speeds (rpm)	
Rated speed, full load	2500
Low idle	900-950
High idle, no load	2580-2680
Horsepower – Rated	
Gross	74 (55.0 kW) @ 2500 rpm
Net	69 (51.0 kW) @ 2500 rpm
Peak torque @ 1400 rpm	
Gross	203 lb-ft (275 N·m)
Net	200 lb-ft (271 N·m)
Torque rise	30%

NOTE: Gross horsepower and torque per ISO 9249.
Net horsepower and torque per ISO 9249.

DRIVETRAIN

Transmission	Hydrostatic transmission	
Pump relief	6,773 psi (46 700 kPa)	
Pump flow	35.9 gpm (136 L/min)	
Differential	Front limited slip w/45% transfer on front axles	
Front axle		
Differential ratio	3.66	
Planetary ratio	6.00	
Final axle ratio	22.00	
Planetaries	Outboard	
Service brakes	Hydraulically actuated, dry disc w/accumulator to front axle & joint shaft	
Parking brake	Mechanical	
Travel speeds – mph (km/h) w/365/80 R20 tires	Forward	Reverse
Low	0-4.0 (0-6.4)	0-4.0 (0-6.4)
High	0-12.4 (0-20)	0-12.4 (0-20)
Optional HTS (High Travel Speed)	Forward	Reverse
Low	0-3.3 (0-5.3)	0-3.3 (0-5.3)
High	0-10.3 (0-16.5)	0-10.3 (0-16.5)
HTS engaged	0-21.7 (0-35)	0-21.7 (0-35)

NOTE: Travel speeds at full engine throttle.

ELECTRICAL

Voltage	12 Volts, negative ground
Alternator	95 amp
Batteries	95 AHR, 900 CCA

HYDRAULICS

Pump (steering/implement)	Open-centered pressure/flow compensated
Fixed gear type	18.5 gpm @ 2500 rpm @ 3916 psi (70 L/min @ 2500 rpm @ 27 000 kPa)
Loader control valve	Open-center, 1 lever loader control w/forward/neutral/reverse switch, float detent
Loader auxiliary steering	Hydraulic orbital center-pivot articulating w/on-demand oil flow
Main relief pressure @ valve	3,626 psi (25 000 kPa)
Filtration	15-micron, full flow replaceable cartridges on return line

CYLINDERS

Lift cylinder	
Bore diameter	3.5 in (90 mm)
Rod diameter	2.0 in (50 mm)
Stroke	28.4 in (721 mm)
Dump cylinder	
Bore diameter	3.5 in (90 mm)
Rod diameter	2.0 in (50 mm)
Stroke	18.0 in (459 mm)

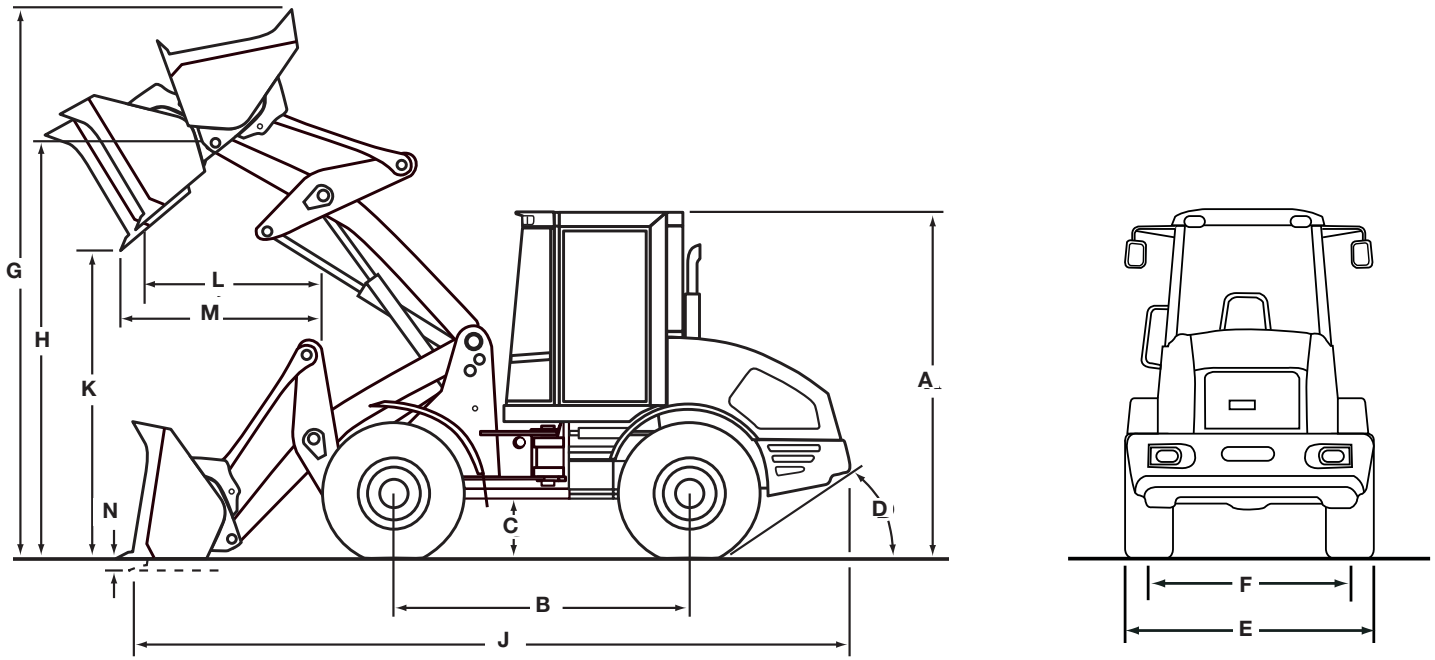

DIMENSIONS

Height to –	
A. Top of ROPS cab	110.7 in (2813 mm)
B. Wheelbase	92.5 in (2350 mm)
C. Ground clearance under shaft	16 in (415 mm)
C. Ground clearance under axles	13 in (330 mm)
D. Angle of departure	35°
Width –	
E. Overall* w/o bucket	75 in (1904 mm)
F. Centerline tread	60.1 in (1526 mm)
Turning radius* – outside	
161.2 in (4095 mm)	
Turning angle –	
From center	41°
Total angle	82°
Rear axle oscillation, total	
24°	

NOTE: *Dimensions taken with 365/80 R20 tires. Additional dimensions on pages 3 & 4.

PERFORMANCE DATA

221E Versa-Boom	1.3 yd³ GP (1.0 m³) Bucket w/Bolt-on Edge	1.18 yd³ GP (0.9 m³) Bucket w/Bolt-on Edge
SAE bucket capacity – struck	1.09 yd ³ (0.83 m ³)	0.85 yd ³ (0.65 m ³)
Heaped	1.31 yd ³ (1.00 m ³)	1.18 yd ³ (0.90 m ³)
Bucket width – outside	82.7 in (2100 mm)	80.7 in (2050 mm)
Bucket weight	948 lb (430 kg)	919 lb (417 kg)
G. Operating height – fully raised w/spillguard	173.4 in (4403 mm)	172 in (4369 mm)
H. Hinge pin height – fully raised	133.3 in (3386 mm)	133.3 in (3386 mm)
J. Overall length – bucket level on ground	221.9 in (5635 mm)	220.5 in (5600 mm)
Dump angle – fully raised	45°	45°
K. Dump height – fully raised, 45° dump	102.3 in (2598 mm)	103.2 in (2622 mm)
L. Bucket reach – fully raised, 45° dump	34.1 in (867 mm)	33.2 in (843 mm)
M. Bucket reach – 7 ft 0 in (2.13 m) height, 45° dump	49.1 in (1247 mm)	48.7 in (1238 mm)
N. Dig depth	3.2 in (81 mm)	3.2 in (82 mm)
Operating load – ISO	4,001 lb (1815 kg)	4,028 lb (1827 kg)
Maximum material density – ISO	3,059 lb/yd ³ (1815 kg/m ³)	3,422 lb/yd ³ (2030 kg/m ³)
Tipping load – ISO		
Straight	9,358 lb (4245 kg)	9,416 lb (4271 kg)
Straight w/optional counterweight	9,933 lb (4506 kg)	9,991 lb (4532 kg)
20° turn	8,002 lb (3629 kg)	8,056 lb (3654 kg)
20° turn w/optional counterweight	8,490 lb (3850 kg)	8,544 lb (3875 kg)
Lift capacity –		
Full height	5,733 lb (2600 kg)	5,768 lb (2616 kg)
Maximum reach	7,810 lb (3543 kg)	7,836 lb (3554 kg)
Ground	11,146 lb (5056 kg)	11,175 lb (5069 kg)
Breakout force w/tilt cylinder	9,723 lb (4410 kg)	10,189 lb (4622 kg)
Maximum rollback –		
Ground	45°	45°
Carry position	52°	51°
@ Maximum reach	54°	54°
@ Full height	54°	54°
Maximum grading angle w/bucket – back dragging	108°	107°
Loader clearance circle	364.7 in (9263 mm)	362.2 in (9199 mm)

INSTRUMENTATION

Electronic Information Center

Displays/Gauges –

- Fuel level
- Hourmeter
- Engine oil temperature

Indicator lights –

- Hydraulic oil temperature
- Alternator
- Work lights*
- Brake pressure
- Parking brake
- Air conditioning*
- Air filter restriction
- Travel direction F/R
- Speed range selected
- Shift pressure*
- Turn signal indicator
- Engine oil temperature
- Engine oil pressure
- Preheating indicator lamp
- High beam lights

Audible alarms –

- Caution alarm
- Critical alarm
- Backup alarm

Horn

NOTE: *If equipped with option.

OPERATOR ENVIRONMENT

Cab w/heat

Key start

Articulated power steering w/tilt column

Fully adjustable, cloth suspension seat

Foot throttle

Single lever electronic speed shift control,
F/N/R switch in loader control handle

Cup holder

Retractable seat belt

Storage tray

Sun screen – front

Defroster

Opening side window – 180°

Dome light

Wipers rear & front

12-volt auxiliary power

External rearview mirrors

R.H. steps

Coat hook

Loader control lockout

LOADER

Versa-Boom loader linkage

Single control for lift and tilt

Positive hold float

Skid steer compatible attachment coupler

CYCLE TIME

Raise w/rated bucket load 6.0 sec

Dump w/rated bucket load

Versa-Boom 1.0 sec

Lower (empty)

Float down 3.0 sec

SERVICE CAPACITIES

Fuel tank 26.0 gal (100 L)

Hydraulic system

Total 17.7 gal (67 L)

Reservoir 10.5 gal (40 L)

Front and rear axle

Total axle (each) 2.1 gal (8.0 L)

Engine oil w/filter 2.3 gal (8.5 L)

Cooling 4.4 gal (16.5 L)

OPERATING WEIGHTS

Versa-Boom

Unit equipped with ROPS cab with heater, standard counterweight, 365/80 R20 Dunlop tires, front and rear fenders, 1.18 yd³ (0.9 m³) general purpose loader bucket w/edge, full fuel, 165 lb (75 kg) operator 11,947 lb (5419 kg)

With optional counterweight 12,268 lb (5564 kg)

STANDARD EQUIPMENT

OPERATOR'S ENVIRONMENT

See page 4

ENGINE

Case 432T/M3

Fuel filter w/water trap

Dual element air cleaner

95 amp alternator

(1) 900 CCA 12-volt battery

Liquid-cooled radiator

LOADER

See page 4

DRIVETRAIN

4-wheel drive

Hydrostatic transmission

Single lever electronic speed shift control,
F/N/R switch in loader control handle

Outboard planetary axles

Limited slip differential, front axle

Transmission oil cooler

Hydraulic dry disc brakes

Mechanical parking brake

HYDRAULICS

3-spool loader control valve

(8) Diagnostic quick couplers

Auxiliary hydraulics

OTHER

Front and rear fenders

Lights –

(2) Front flood lights

(2) Front driving headlights (high/low beam)

(2) Stop/tail lights and backup light

Front and rear turn signal/flash

Drawbar pin

Articulation locking pin

Tie-down points – front/rear

Backup alarm

Wired for radio

Bucket position indicator

OPTIONAL EQUIPMENT

OPERATOR'S COMPARTMENT

Cab air conditioning w/heater

Rotating beacon

Limited slip option, rear axle

High travel speed (HTS)

0-21.7 mph (0-35 km/h)

Radio ready antenna and speakers

OTHER

(2) Rear flood lights

Tool box

LOADER

Bucket position indicator

Buckets (see page 3)

General Purpose

4-IN-1

Forks

Ride control

Return To Dig

TIRES

365/80 R20 EM SPT9

405/70 R20 SPT9

375/75 R20 XM27

COUNTERWEIGHT

321 lb (146 kg)

Mounts on rear chassis

This page intentionally left blank.

NOTE: All specifications are stated in accordance with SAE Standards or Recommended Practices, where applicable.

NOTE: All engines meet current EPA emissions requirements.

IMPORTANT: Case Construction Equipment Inc. reserves the right to change these specifications without notice and without incurring any obligation relating to such change. Case Construction Equipment Inc. does not warrant the safety or reliability of attachments from other manufacturers.

Case is a registered trademark of CNH America LLC. Any trademarks referred to herein, in association with goods and/or services of companies other than CNH America LLC, are the property of those respective companies.



www.casece.com